

HYDRAULIC MOTORS RW

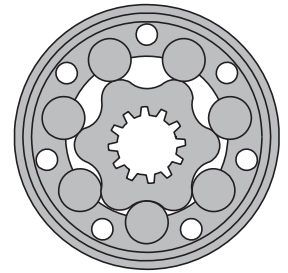

APPLICATION

- » Conveyors
- » Feeding mechanism of robots and manipulators
- » Metal working machines
- » Textile machines
- » Agricultural machines
- » Food industries
- » Grass cutting machinery etc.



CONTENTS

Specification data	85
Function diagrams	86÷90
Permissible shaft seal pressure	90
Dimensions and mounting	91
Permissible shaft loads	92
Shaft extensions	92
Order code	92

OPTIONS

- » Model - Spool valve, roll-gerotor
- » Flange mount
- » Shafts - straight, splined and tapered
- » Metric and BSPP ports
- » Other special features

GENERAL

Max. Displacement,	cm ³ /rev [in ³ /rev]	397 [24.4]
Max. Speed,	[RPM]	1029
Max. Torque,	daNm [lb-in]	cont.: 61 [5400] int.: 69 [6100]
Max. Output,	kW [HP]	15 [20.1]
Max. Pressure Drop,	bar [PSI]	cont.: 175 [2540] int.: 200 [2900]
Max. Oil Flow,	lpm [GPM]	90 [19.8]
Min. Speed,	[RPM]	10
Pressure fluid		Mineral based- HLP(DIN 51524) or HM(ISO 6743/4)
Temperature range,	°C [°F]	-40÷140 [-40÷284]
Optimal Viscosity range,	mm ² /s [SUS]	20÷75 [98÷347]
Filtration		ISO code: 18/16/13 According to ISO 4406-1999

Oil flow in drain line

Pressure drop bar [PSI]	Viscosity mm ² /s [SUS]	Oil flow in drain line lpm [GPM]
100 [1450]	20 [98]	2,5 [.660]
	35 [164]	1,8 [.476]
140 [2030]	20 [98]	3,5 [.925]
	35 [164]	2,8 [.740]

Pressure Losses

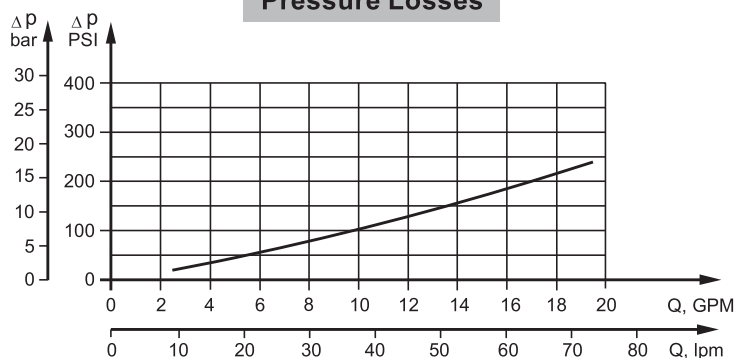

SPECIFICATION DATA

Type		RW 50	RW 80	RW 100	RW 125	RW 160	RW 200	RW 250	RW 315	RW 400
Displacement, cm³/rev		51,5	80,3	99,8	125,7	159,6	199,8	250,1	315,7	397
	[in³/rev]	[3.14]	[4.90]	[6.09]	[7.67]	[9.74]	[12.19]	[15.26]	[19.26]	[24.4]
Max. Speed, [RPM]	Cont.	775	750	600	475	375	300	300	240	190
	Int.*	1029	940	750	600	470	375	360	285	226
Max. Torque, daNm [lb-in]	Cont.	10 [900]	20 [1770]	24 [2125]	30 [2655]	39 [3450]	45 [4000]	54 [4780]	55 [4870]	61 [5400]
	Int.*	13 [1150]	22 [1947]	28 [2480]	34 [3010]	43 [3805]	50 [4425]	61 [5400]	69 [6100]	69 [6100]
	Peak**	17 [1505]	27 [2390]	32 [2832]	37 [3275]	46 [4070]	56 [4960]	71 [6280]	84 [7430]	87 [7700]
Max. Output, kW [HP]	Cont.	7 [9.5]	12,5 [17]	13 [17.4]	12,5 [16.8]	11,5 [15.4]	11 [14.8]	10 [13.4]	9 [12]	7,8 [10.5]
	Int.*	8,5 [11.9]	15 [20.1]	15 [20.1]	14,5 [19.5]	14 [18.8]	13 [17.4]	12 [16.1]	10 [13.4]	10,6 [14.2]
Max. Pressure Drop, bar [PSI]	Cont.	140 [2030]	175 [2540]	175 [2540]	175 [2540]	175 [2540]	175 [2540]	175 [2540]	135 [1960]	110 [1600]
	Int.*	175 [2540]	200 [2900]	200 [2900]	200 [2900]	200 [2900]	200 [2900]	200 [2900]	175 [2540]	140 [2030]
	Peak**	225 [3260]	225 [3260]	225 [3260]	225 [3260]	225 [3260]	225 [3260]	225 [3260]	210 [3045]	175 [2540]
Max. Oil Flow, lpm [GPM]	Cont.	40 [10,6]	60 [15,9]	60 [15,9]	60 [15,9]	60 [15,9]	60 [15,9]	75 [19,8]	75 [19,8]	75 [19,8]
	Int.*	50 [13,2]	75 [19,8]	75 [19,8]	75 [19,8]	75 [19,8]	75 [19,8]	90 [23,8]	90 [23,8]	90 [23,8]
Max. Inlet Pressure, bar [PSI]	Cont.	175 [2540]	175 [2540]	175 [2540]	175 [2540]	175 [2540]	175 [2540]	175 [2540]	175 [2540]	175 [2540]
	Int.*	200 [2900]	200 [2900]	200 [2900]	200 [2900]	200 [2900]	200 [2900]	200 [2900]	200 [2900]	200 [2900]
	Peak**	225 [3260]	225 [3260]	225 [3260]	225 [3260]	225 [3260]	225 [3260]	225 [3260]	225 [3260]	225 [3260]
Max. Return Pressure with Drain Line, bar [PSI]	Cont.	175 [2540]	175 [2540]	175 [2540]	175 [2540]	175 [2540]	175 [2540]	175 [2540]	175 [2540]	175 [2540]
	Int.*	200 [2900]	200 [2900]	200 [2900]	200 [2900]	200 [2900]	200 [2900]	200 [2900]	200 [2900]	200 [2900]
	Peak**	225 [3260]	225 [3260]	225 [3260]	225 [3260]	225 [3260]	225 [3260]	225 [3260]	225 [3260]	225 [3260]
Max. Starting Pressure with Unloaded Shaft, bar [PSI]		10 [145]	10 [145]	10 [145]	9 [130]	7 [102]	5 [73]	5 [73]	5 [73]	5 [73]
Min. Starting Torque, daNm [lb-in]	At max.press. drop Cont.	8 [710]	15 [1330]	20 [1770]	25 [2215]	32 [2832]	41 [3630]	50 [4425]	50 [4425]	50 [4425]
	At max.press. drop Int.*	10 [885]	17 [1505]	23 [2035]	28 [2480]	37 [3275]	46 [4070]	55 [4870]	66 [5840]	61 [5400]
Min. Speed***, [RPM]		10	10	10	10	10	10	10	10	10
Weight, kg [lb]		9,6	9,7	9,8	10,0	10,3	10,8	11,3	11,8	12,5
		[21.2]	[21.4]	[21.7]	[22.1]	[22.7]	[23.8]	[24.9]	[26]	[27.63]

* Intermittent operation: the permissible values may occur for max. 10% of every minute.

** Peak load: the permissible values may occur for max. 1% of every minute.

*** For speeds lower than given, consult factory or your regional manager.

- Intermittent speed and intermittent pressure must not occur simultaneously.
- Recommended filtration is per ISO cleanliness code 20/16. A nominal filtration of 25 micron or better.
- Recommend using a premium quality, anti-wear type mineral based hydraulic oil HLP(DIN51524) or HM (ISO 6743/4).
If using synthetic fluids consult the factory for alternative seal materials.
- Recommended minimum oil viscosity 13 mm²/s [70 SUS] at 50°C [122°F].
- Recommended maximum system operating temperature is 82°C [180°F].
- To assure optimum motor life fill with fluid prior to loading and run at moderate load and speed for 10-15 minutes.

FUNCTION DIAGRAMS

RW 50

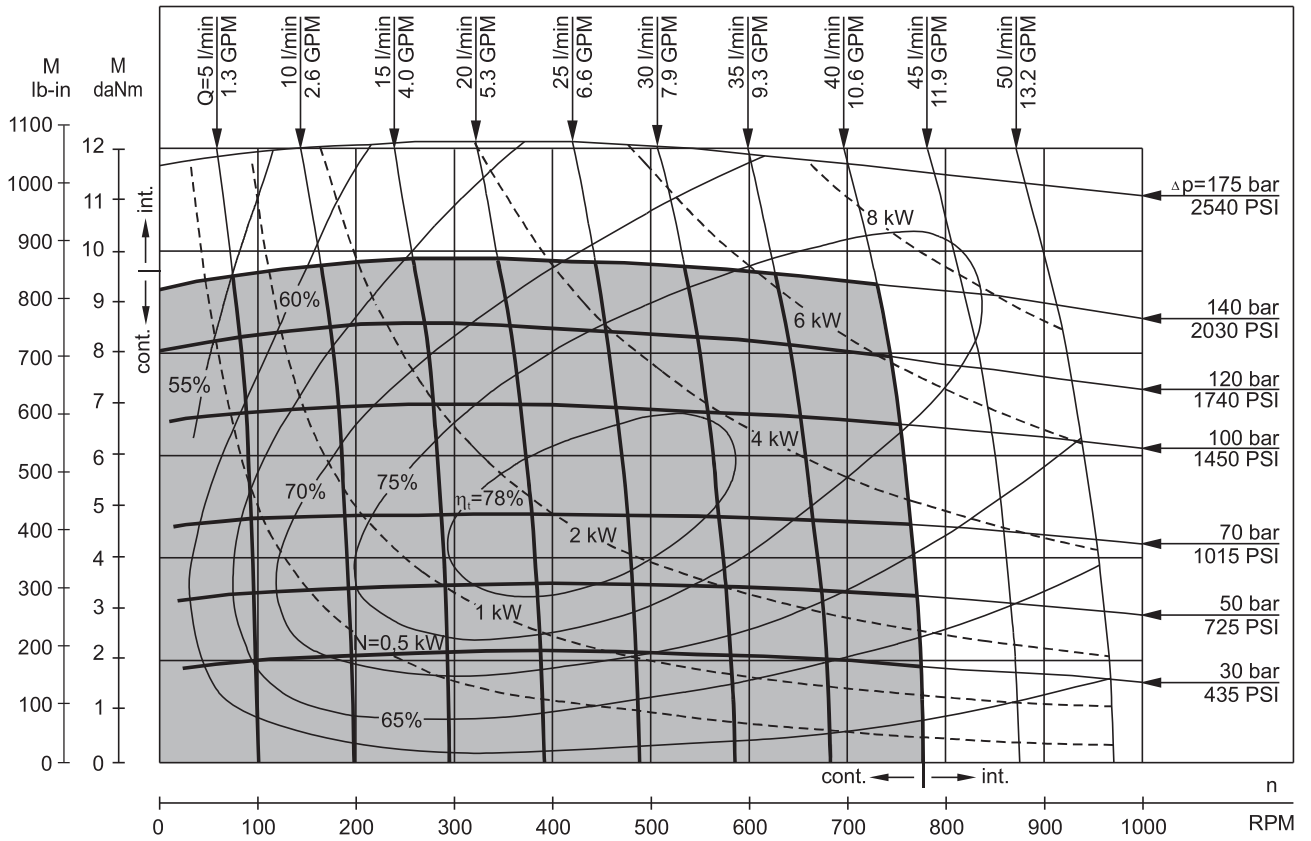

RW 80

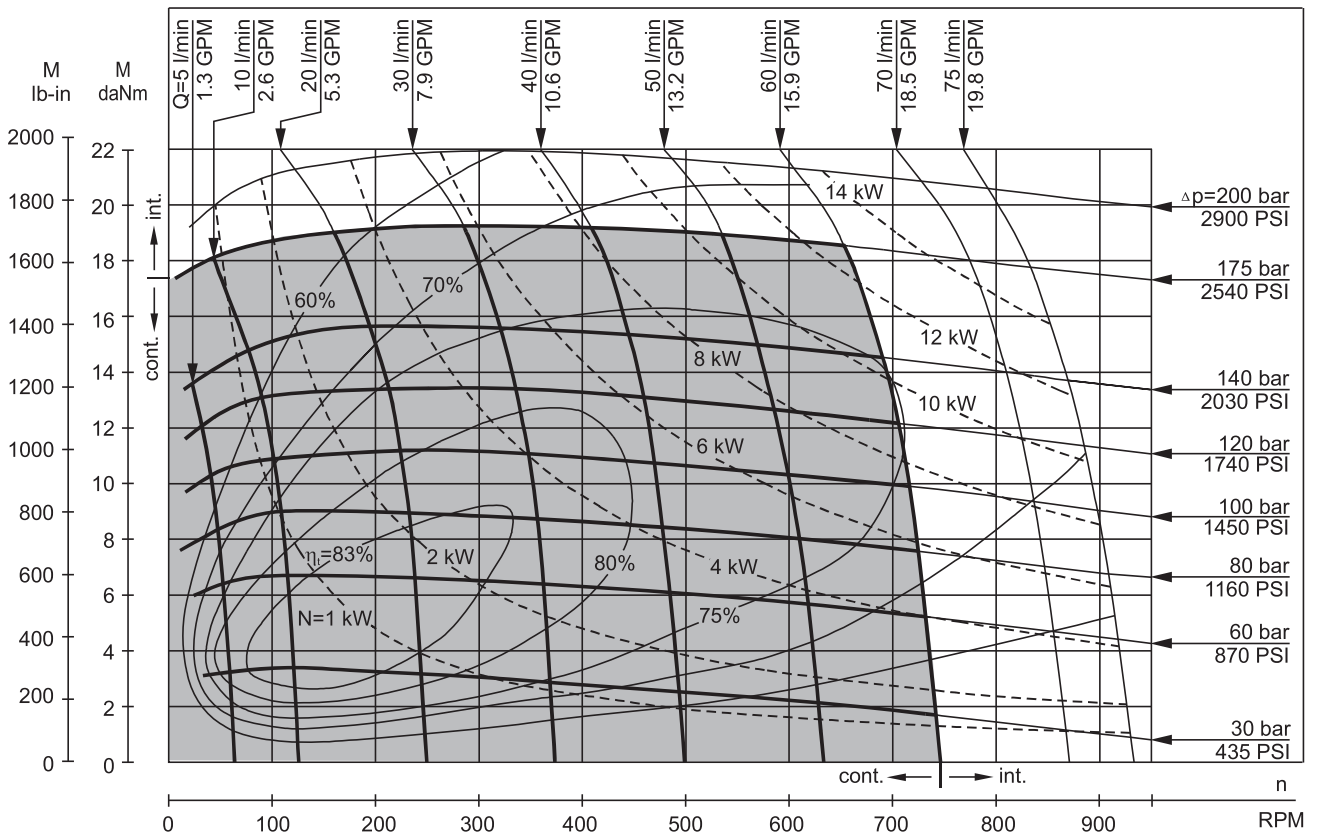

The function diagrams data is for average performance of randomly selected motors at back pressure 5÷10 bar [72.5 PSI÷145 PSI] and oil with viscosity of 32 mm²/s [150 SUS] at 50°C [122°F].

FUNCTION DIAGRAMS

RW 100

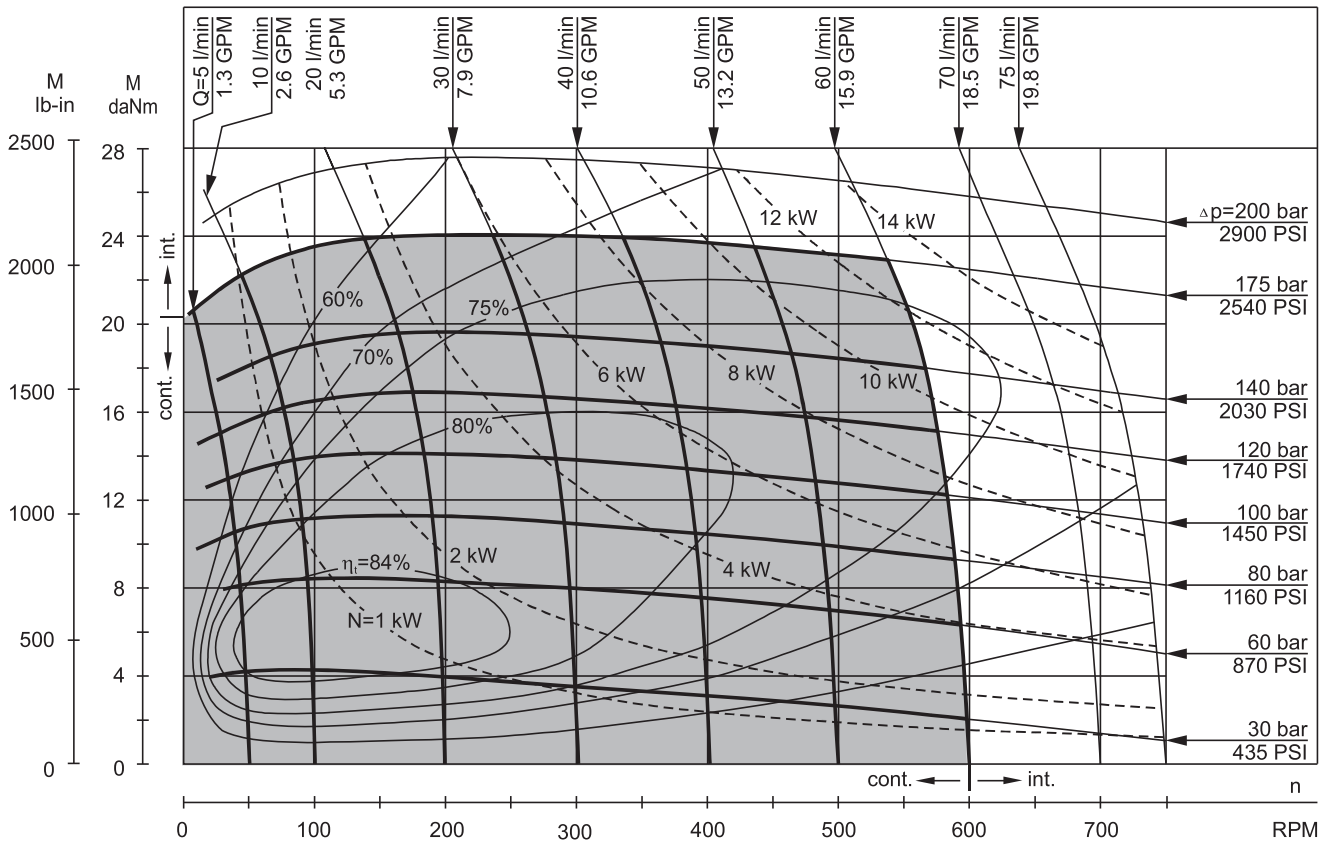

RW 125

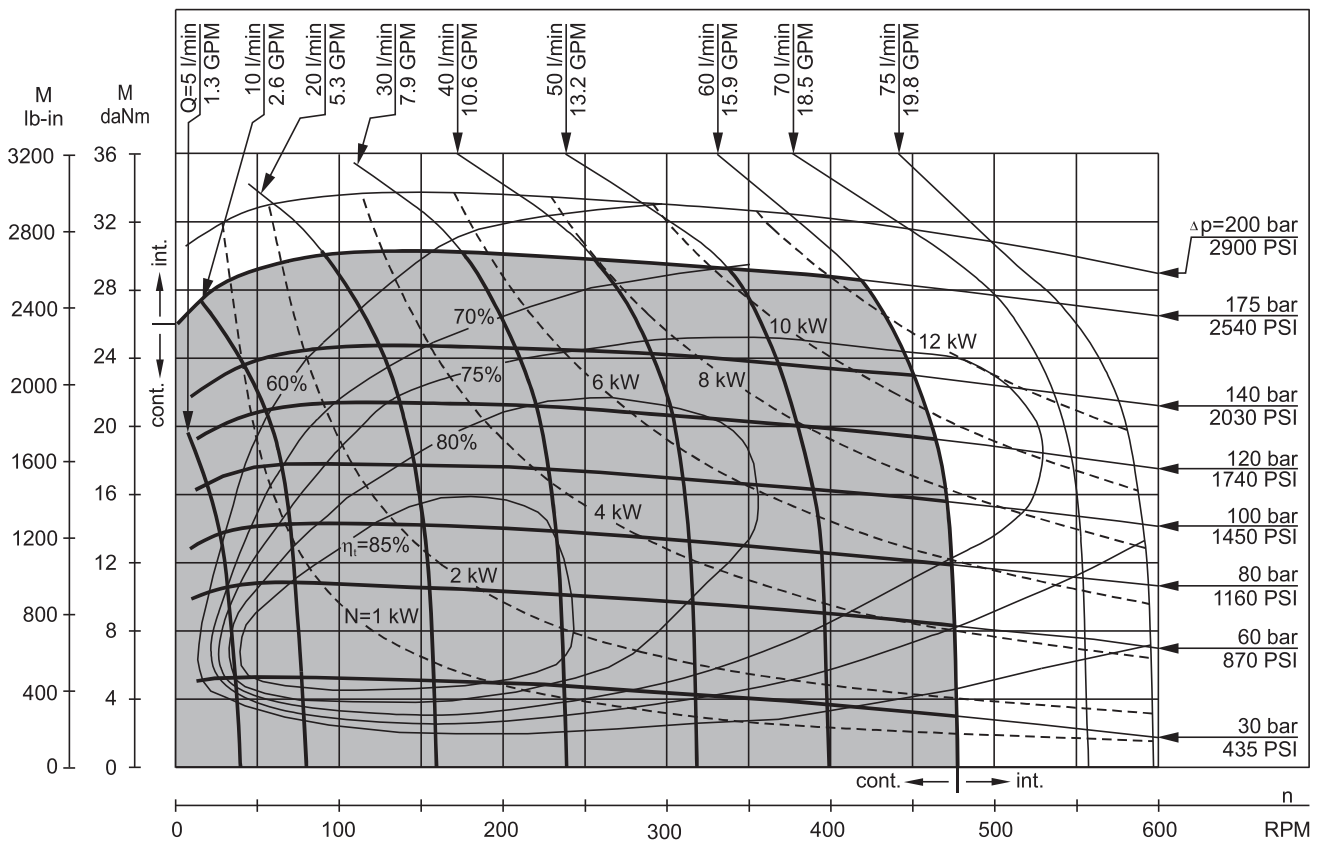

The function diagrams data is for average performance of randomly selected motors at back pressure 5÷10 bar [72.5 PSI÷145 PSI] and oil with viscosity of 32 mm²/s [150 SUS] at 50°C [122°F].

FUNCTION DIAGRAMS

RW 160

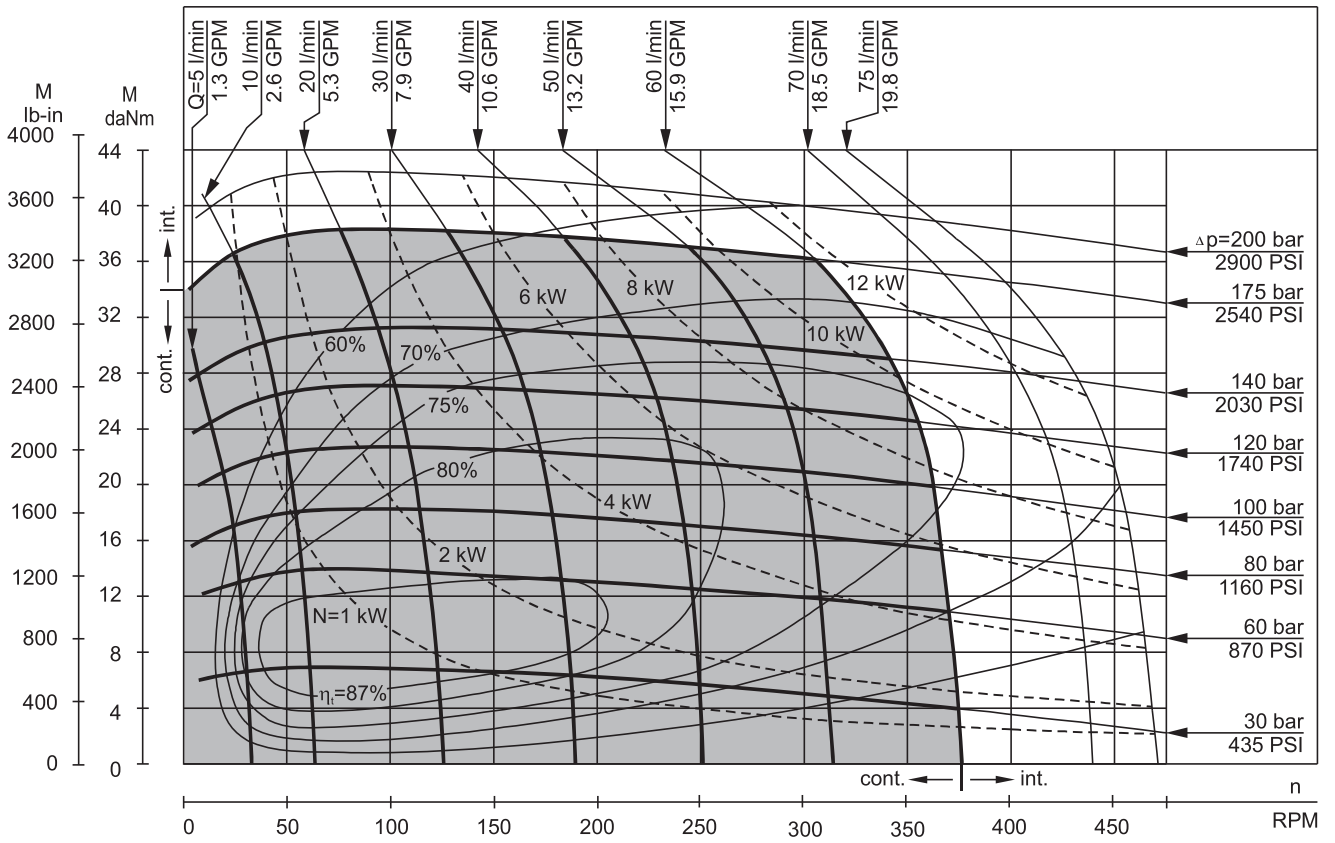

RW 200

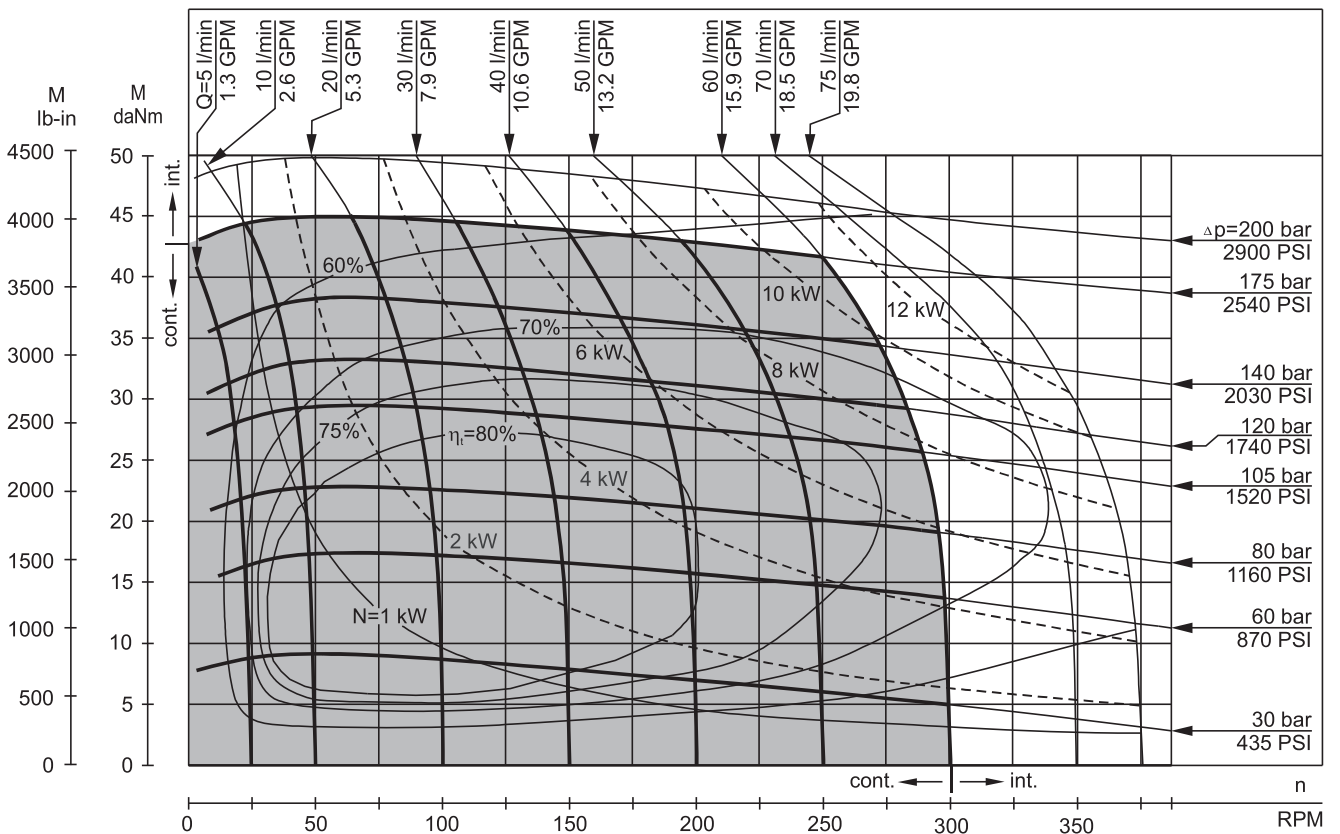

The function diagrams data is for average performance of randomly selected motors at back pressure 5÷10 bar [72.5 PSI÷145 PSI] and oil with viscosity of 32 mm²/s [150 SUS] at 50°C [122°F].

FUNCTION DIAGRAMS

RW 250

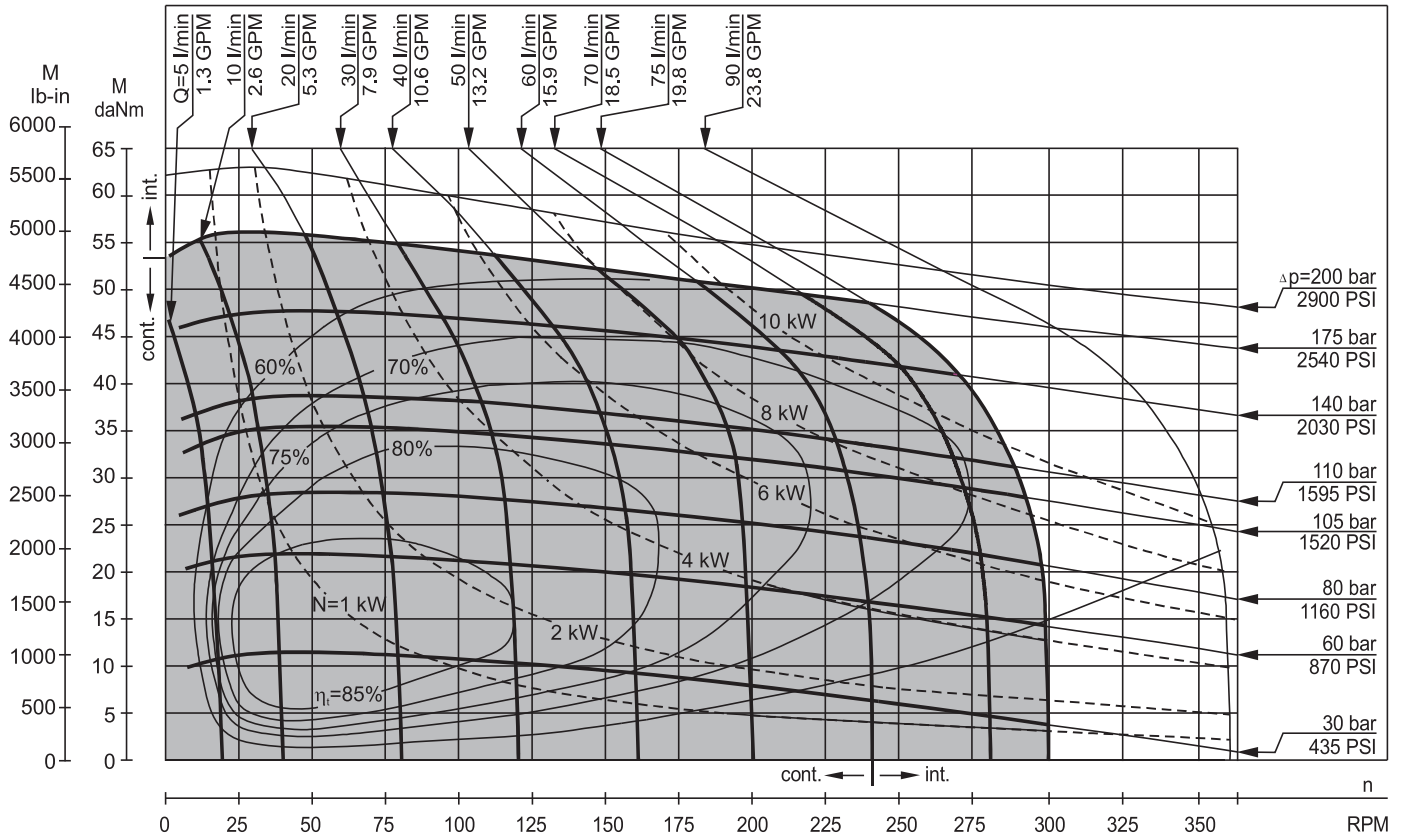

RW 315

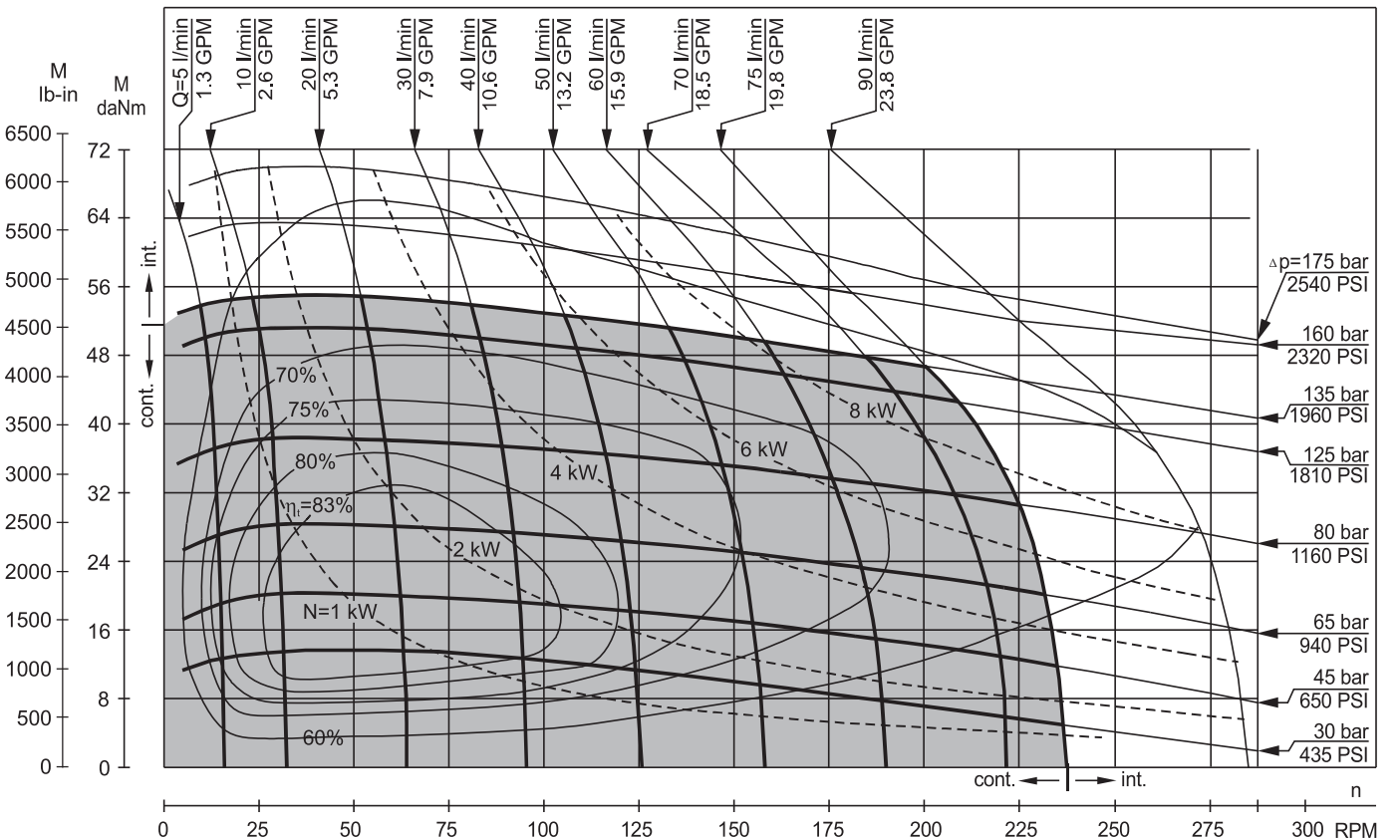

The function diagrams data is for average performance of randomly selected motors at back pressure 5÷10 bar [72.5 PSI÷145 PSI] and oil with viscosity of 32 mm²/s [150 SUS] at 50°C [122°F].

FUNCTION DIAGRAMS

RW 400

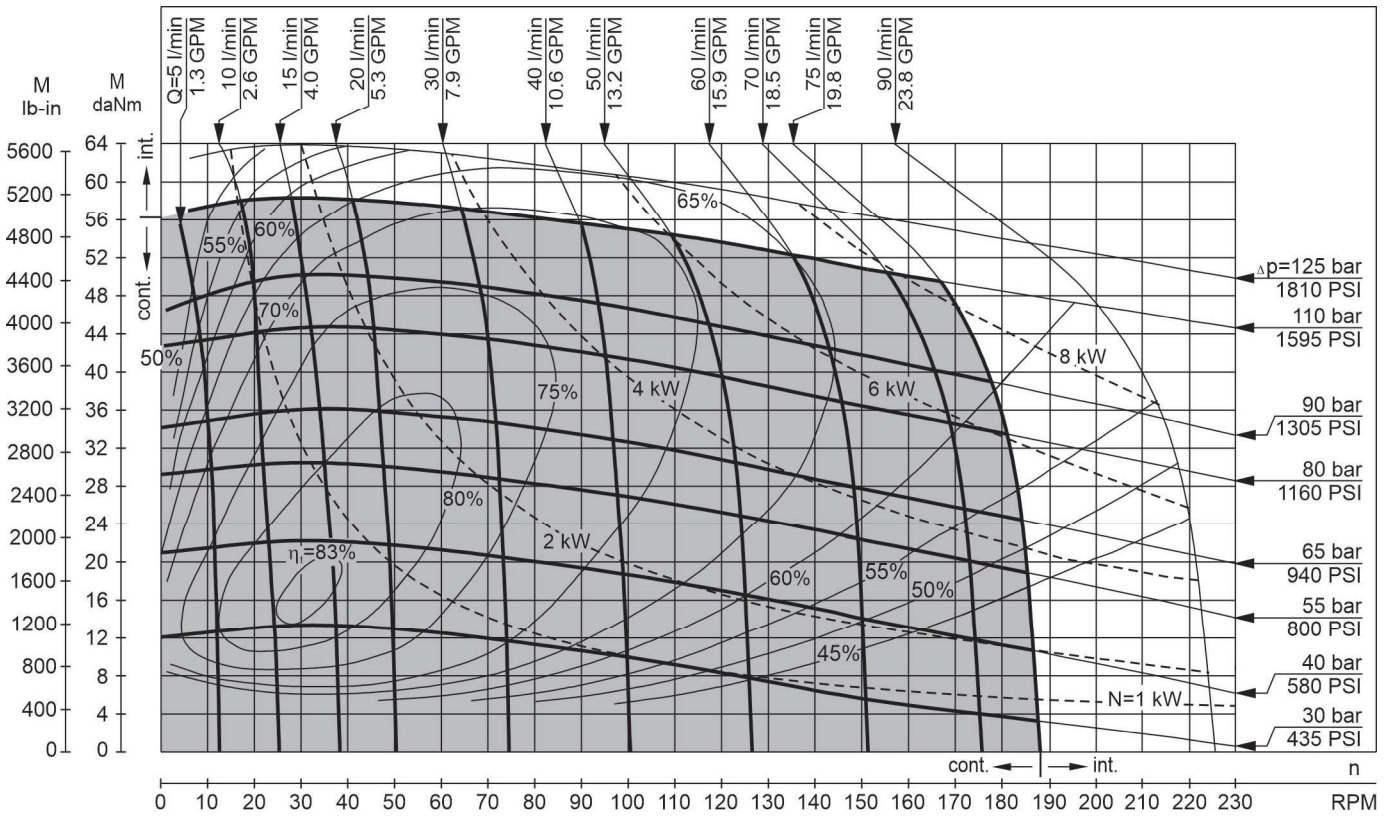

The function diagrams data is for average performance of randomly selected motors at back pressure 5÷10 bar [72.5 PSI÷145 PSI] and oil with viscosity of 32 mm²/s [150 SUS] at 50°C [122°F].

MAX. PERMISSIBLE SHAFT SEAL PRESSURE

RW...; RW...UK motors with drain connection:

The shaft seal pressure equals the pressure in the drain line.

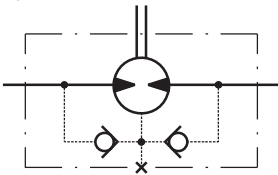

RW...1 motors without drain connection:

The shaft seal pressure never exceeds the pressure in the return line.

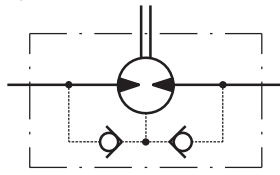

RW...U motors with high pressure seal and drain connection:

The shaft seal pressure equals the pressure in the drain line.

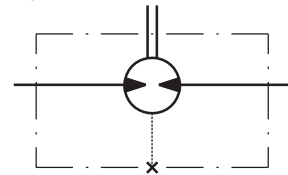

Max. return pressure without drain line or max. pressure in the drain line

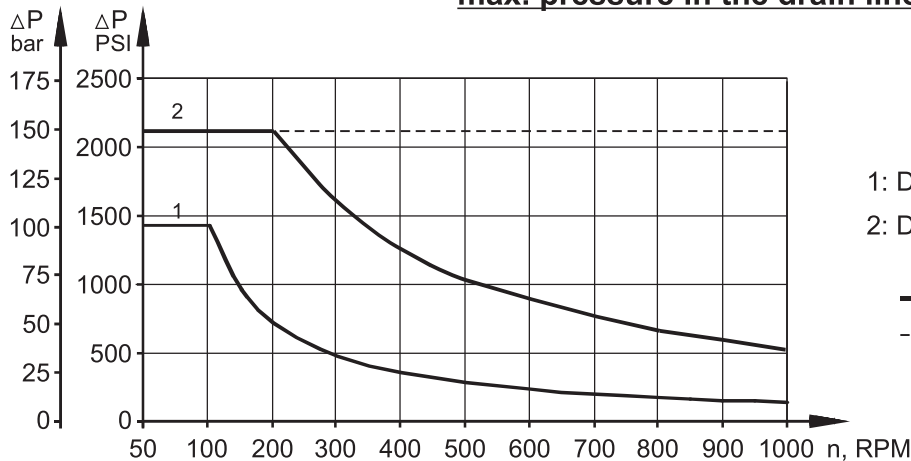

- 1: Drawing for Standard Shaft Seal
- 2: Drawing for High Pressure Seal ("U" Seal)

— - continuous operations
- - - - intermittent operations

DIMENSIONS and MOUNTING DATA

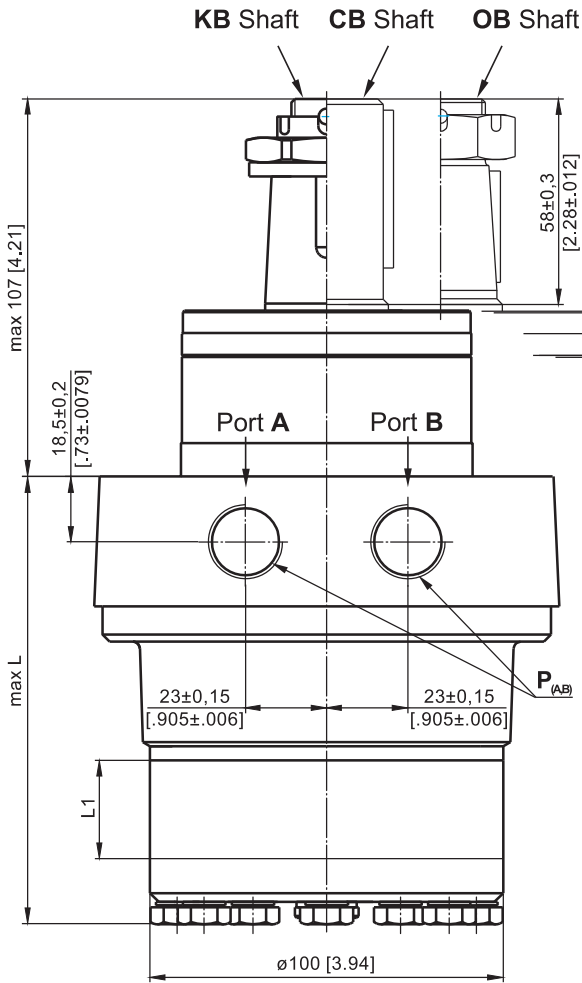

Shaft Dim.
See Page 92

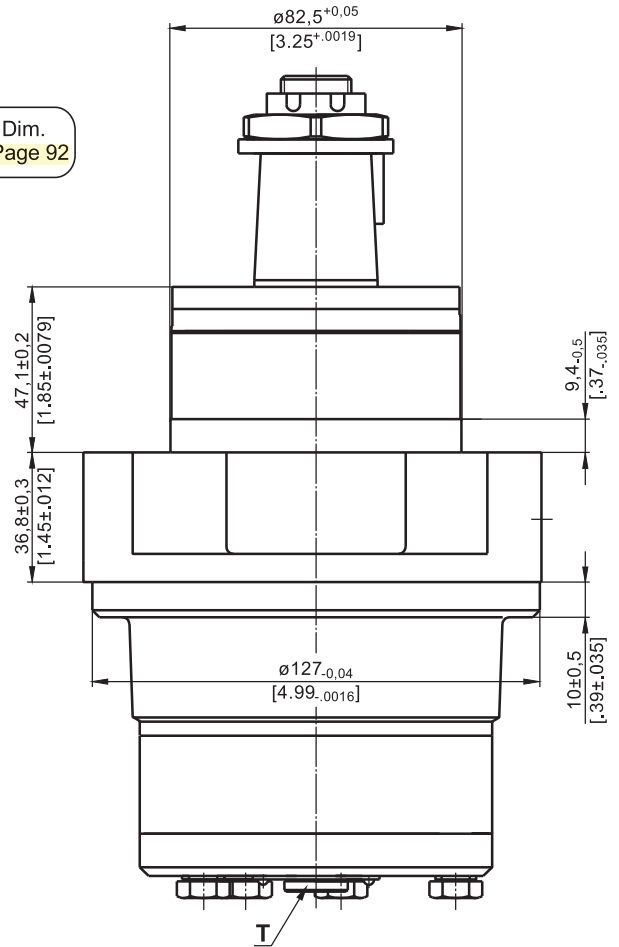

Type	L, mm [in]	L1, mm [in]
RW 50	108,0 [4.25]	9,0 [.35]
RW 80	113,0 [4.45]	14,0 [.55]
RW 100	116,5 [4.59]	17,4 [.69]
RW 125	120,5 [4.74]	21,8 [.86]
RW 160	126,5 [4.98]	27,8 [1.09]
RW 200	133,5 [5.26]	34,8 [1.37]
RW 250	142,5 [5.61]	43,5 [1.71]
RW 315	153,5 [6.04]	54,8 [2.16]
RW 400	168,5 [6.63]	69,4 [2.73]

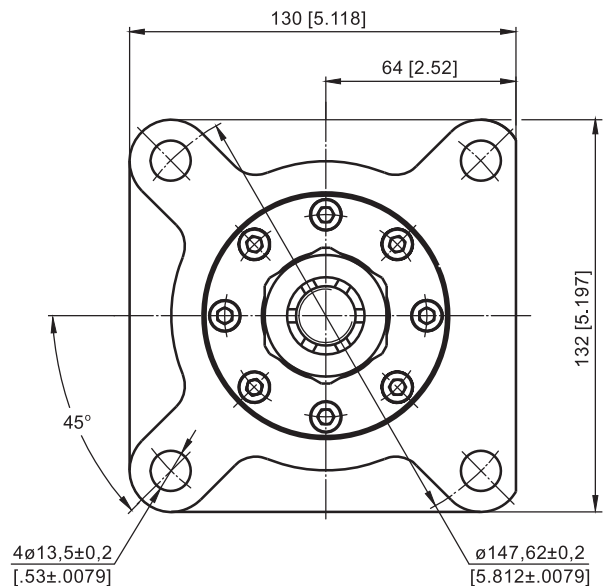

P_(A,B) : 2xG1/2 or 2xM22x1,5 - 17 mm [.67 in] depth
T : G1/4 or M14x1,5 - 12 mm [.47 in] depth (plugged)

Standard Rotation
Viewed from Shaft End
Port A Pressurized - **CW**
Port B Pressurized - **CCW**

Reverse Rotation
Viewed from Shaft End
Port A Pressurized - **CCW**
Port B Pressurized - **CW**



SHAFT EXTENSIONS

CB - $\varnothing 32$ straight, Parallel key A10x8x45 DIN 6885
Max. Torque 77 daNm [6815 lb-in]

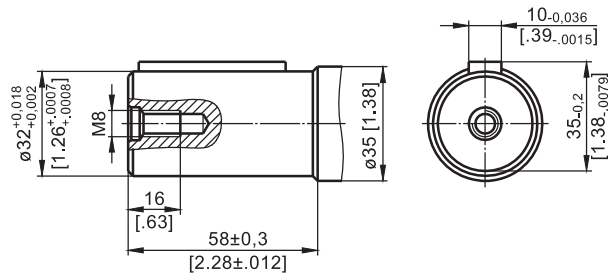

KB - tapered 1:10, Parallel key B6x6x20 DIN 6885
Max. Torque 95 daNm [8400 lb-in]

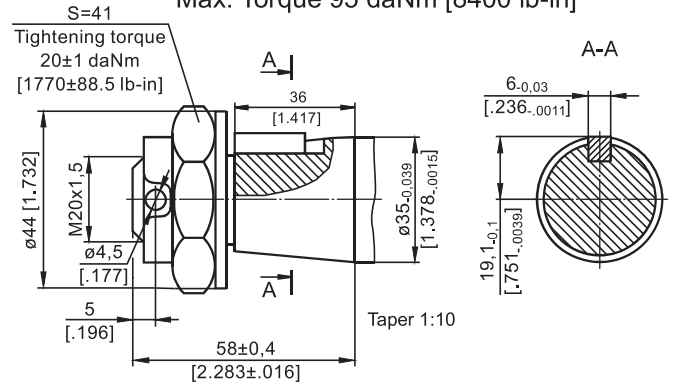

OB - tapered 1:8 SAEJ 501, Parallel key $\frac{5}{16} \times \frac{5}{16} \times 1\frac{1}{4}$ BS46
Max. Torque 77 daNm [6815 lb-in]

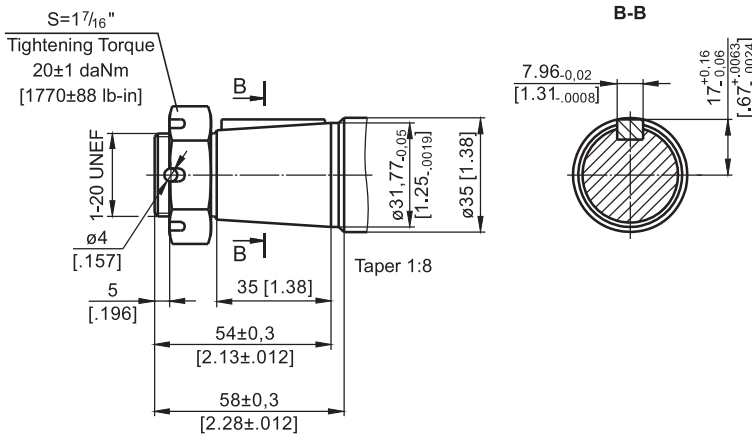

1. Permissible radial shaft load
2. Drawing by n= 50 rpm
3. Drawing by n=100 rpm
4. Drawing by n=200 rpm
5. Drawing by n=400 rpm

PERMISSIBLE SHAFT LOADS

The curve applies to a B10 bearing life of 2000 hours.

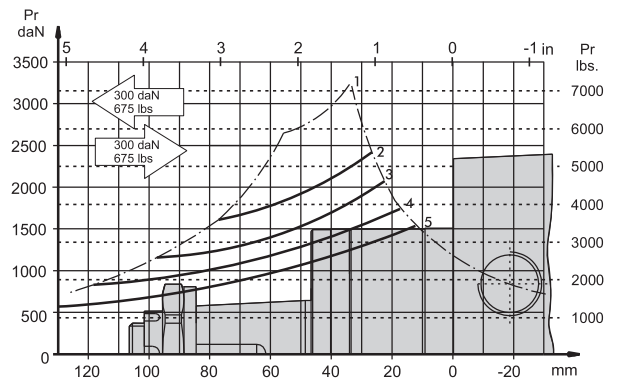

ORDER CODE

1	2	3	4	5	6	7
R W						

Pos.1 - Displacement code

50	- 51,5 cm ³ /rev [3.14 in ³ /rev]
80	- 80,3 cm ³ /rev [4.90 in ³ /rev]
100	- 99,8 cm ³ /rev [6.09 in ³ /rev]
125	- 125,7 cm ³ /rev [7.67 in ³ /rev]
160	- 159,6 cm ³ /rev [9.74 in ³ /rev]
200	- 199,8 cm ³ /rev [12.19 in ³ /rev]
250	- 250,1 cm ³ /rev [15.26 in ³ /rev]
315	- 315,7 cm ³ /rev [19.26 in ³ /rev]
400	- 397,0 cm ³ /rev [24.40 in ³ /rev]

Pos.2 - Shaft Extensions*

CB	- $\varnothing 32$ straight, Parallel key A10x8x45 DIN6885
KB	- $\varnothing 35$ tapered 1:10, Parallel key B6x6x20 DIN6888
OB	- $\varnothing 1\frac{1}{4}$ tapered 1:8, Parallel key $\frac{5}{16} \times \frac{5}{16} \times 1\frac{1}{4}$ BS46

Pos.3 - Shaft Seal Version

omit	- Standard shaft seal
U	- High pressure shaft seal without check valves
UK	- High pressure shaft seal with check valves

Pos.4 - Drain Port

omit	- with drain port
1	- without drain port

Pos.5 - Ports

omit	- BSPP (ISO 228)
M	- Metric (ISO 262)

Pos.6 - Additional Options (see page 125)

Pos.7 - Design Series

omit	- Factory specified
------	---------------------

NOTES: * The permissible output torque for shafts must not be exceeded!
The hydraulic motors are mangano-phosphatized as standard.