

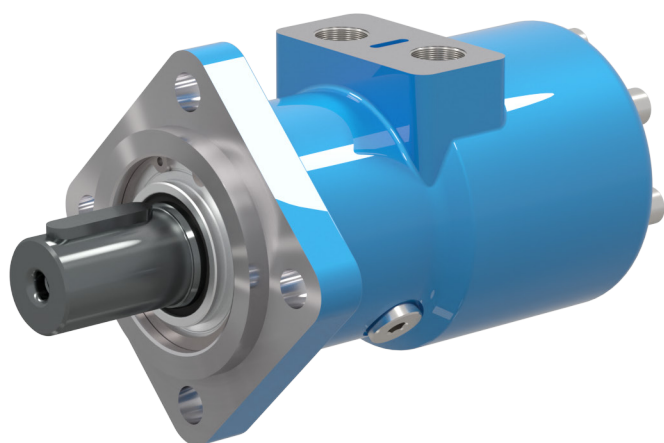

SAMHYDRAULIK™



AR Orbital Motors



Motor Features	D2
Range	D3
Versions	D3
Motor Technical Specifications	D4
Performance Curves	D5
Pressure Data	D10
Max. Permissible Shaft Pressure	D10
Pressure Loss	D11
Other Informations	D12
Ordering Code	D13
Dimensions and Weight	D14
Shaft End	D18
Options	D19

Click **i** button to return to main index

Click **DANA** button to return to section index



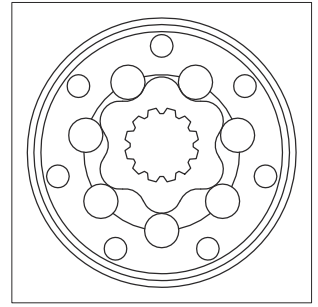
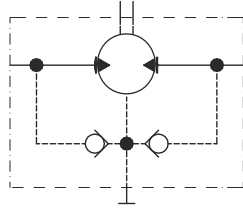
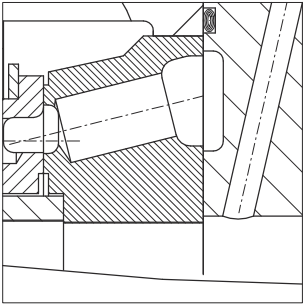

7 sockets - 6 teeth roller set.

Pressure compensated valve plate maintains minimal leakage and provides compensated wear.

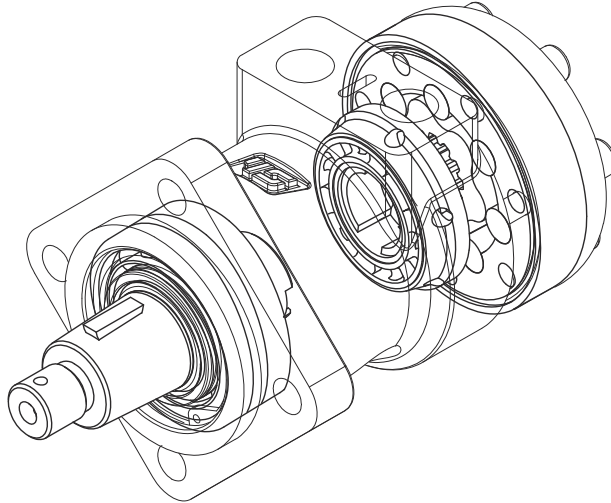

Built-in check valves to relieve case pressure to the low pressure side of the motor and adequate for application without the need to connect the drain.

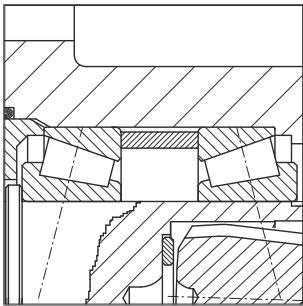

Two options of bearing for heavy shaft loads.

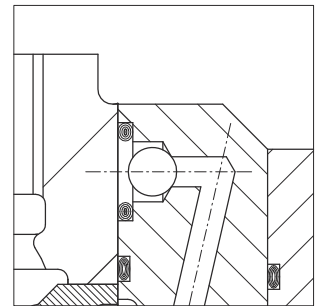

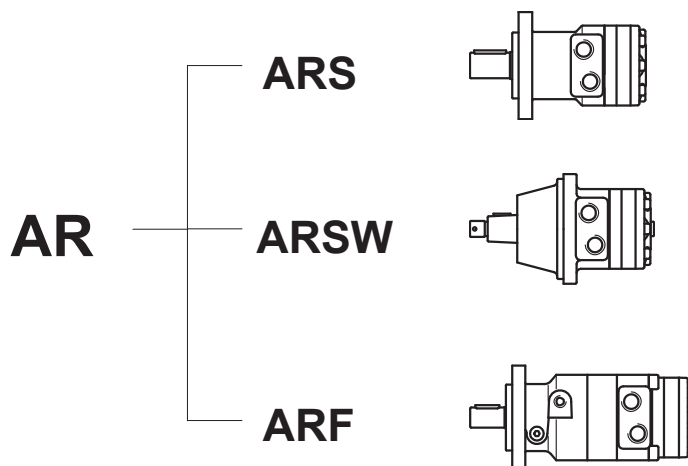

Versions

HPS
High Pressure Seal

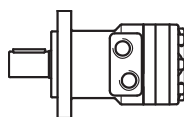

Available with motor

ARS

FP
Brake motor

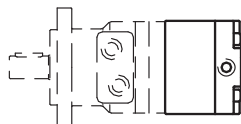

ARS - ARSW

.../N..
Dual shaft oval flange



ARS - ARF

.../D..
Dual shaft square flange



ARS - ARF

TAC
Rev-counter connection

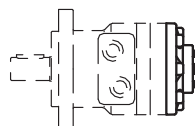

ARS - ARF

TAC - E
Electronic tachometer

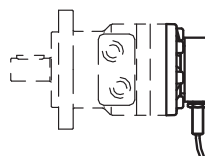

ARS - ARF

Motor	Displacement cm ³ /rev [in ³ /rev]	Max. input pressure bar [psi]		Max. differential pressure bar [psi]		Max. torque Nm [lbf-ft]		Max. flow l/min [U.S. gpm]		Max. speed rpm		Max. power kW [hp]	
		Cont Int ¹⁾ Peak ²⁾	175 [2538] 190 [2755] 250 [3625]	Cont Int ¹⁾ Peak ²⁾	160 [2320] 190 [2755] 250 [3625]	Cont Int ¹⁾	118 [86.9] 136 [100.2]	Cont Int ¹⁾	40 [11] 50 [13]	Cont Int ¹⁾	775 970	Cont Int ¹⁾	8.5 [11.3] 10.2 [13.6]
AR 50	51.6 [3.14]	Cont Int ¹⁾ Peak ²⁾	175 [2538] 190 [2755] 250 [3625]	Cont Int ¹⁾ Peak ²⁾	160 [2320] 190 [2755] 250 [3625]	Cont Int ¹⁾	118 [86.9] 136 [100.2]	Cont Int ¹⁾	40 [11] 50 [13]	Cont Int ¹⁾	775 970	Cont Int ¹⁾	8.5 [11.3] 10.2 [13.6]
AR 80	80.4 [4.9]	Cont Int ¹⁾ Peak ²⁾	175 [2538] 190 [2755] 250 [3625]	Cont Int ¹⁾ Peak ²⁾	160 [2320] 190 [2755] 250 [3625]	Cont Int ¹⁾	184 [135.6] 210 [154.7]	Cont Int ¹⁾	60 [16] 75 [20]	Cont Int ¹⁾	746 933	Cont Int ¹⁾	12.6 [16.8] 15.2 [20.3]
AR 100	100 [6.1]	Cont Int ¹⁾ Peak ²⁾	175 [2538] 190 [2755] 250 [3625]	Cont Int ¹⁾ Peak ²⁾	160 [2320] 190 [2755] 250 [3625]	Cont Int ¹⁾	230 [169.5] 260 [191.6]	Cont Int ¹⁾	60 [16] 75 [20]	Cont Int ¹⁾	600 750	Cont Int ¹⁾	13 [17.4] 15.5 [20.7]
AR 130	125.7 [7.66]	Cont Int ¹⁾ Peak ²⁾	175 [2538] 190 [2755] 250 [3625]	Cont Int ¹⁾ Peak ²⁾	150 [2175] 190 [2755] 250 [3625]	Cont Int ¹⁾	270 [198.9] 330 [243.2]	Cont Int ¹⁾	60 [16] 75 [20]	Cont Int ¹⁾	477 597	Cont Int ¹⁾	12 [16] 14.2 [19]
AR160	160 [9.76]	Cont Int ¹⁾ Peak ²⁾	175 [2538] 190 [2755] 250 [3625]	Cont Int ¹⁾ Peak ²⁾	150 [2175] 190 [2755] 250 [3625]	Cont Int ¹⁾	340 [250.5] 420 [309.5]	Cont Int ¹⁾	60 [16] 75 [20]	Cont Int ¹⁾	375 470	Cont Int ¹⁾	12.4 [16.6] 15.7 [21]
AR 200	200 [12.2]	Cont Int ¹⁾ Peak ²⁾	175 [2538] 190 [2755] 250 [3625]	Cont Int ¹⁾ Peak ²⁾	125 [1813] 175 [2538] 230 [3335]	Cont Int ¹⁾	350 [257.9] 480 [353.7]	Cont Int ¹⁾	65 [17] 75 [20]	Cont Int ¹⁾	325 375	Cont Int ¹⁾	10.8 [14.4] 15.5 [20.7]
AR 250	250 [15.2]	Cont Int ¹⁾ Peak ²⁾	175 [2538] 190 [2755] 250 [3625]	Cont Int ¹⁾ Peak ²⁾	110 [1595] 155 [2248] 200 [2900]	Cont Int ¹⁾	380 [280] 520 [383.2]	Cont Int ¹⁾	65 [17] 80 [21]	Cont Int ¹⁾	260 320	Cont Int ¹⁾	9.8 [13.1] 13.4 [17.9]
AR 315	314 [19.2]	Cont Int ¹⁾ Peak ²⁾	175 [2538] 190 [2755] 250 [3625]	Cont Int ¹⁾ Peak ²⁾	80 [1160] 120 [1740] 150 [2175]	Cont Int ¹⁾	340 [250.5] 510 [375.8]	Cont Int ¹⁾	65 [17] 80 [21]	Cont Int ¹⁾	207 254	Cont Int ¹⁾	6.1 [8.1] 8.5 [11.3]
AR 400	393 [23.9]	Cont Int ¹⁾ Peak ²⁾	175 [2538] 190 [2755] 250 [3625]	Cont Int ¹⁾ Peak ²⁾	65 [943] 100 [1450] 120 [1740]	Cont Int ¹⁾	358 [263.8] 510 [375.8]	Cont Int ¹⁾	65 [17] 80 [21]	Cont Int ¹⁾	165 203	Cont Int ¹⁾	4.7 [6.2] 6 [8]

Test conditions: 37 cSt oil at 45°C.

¹⁾ Intermittent duty must not exceed 10% each minute.

²⁾ Peak duty must not exceed 1% each minute.

Click **DANA** button to return to section index

Click **i** button to return to main index



AR 50

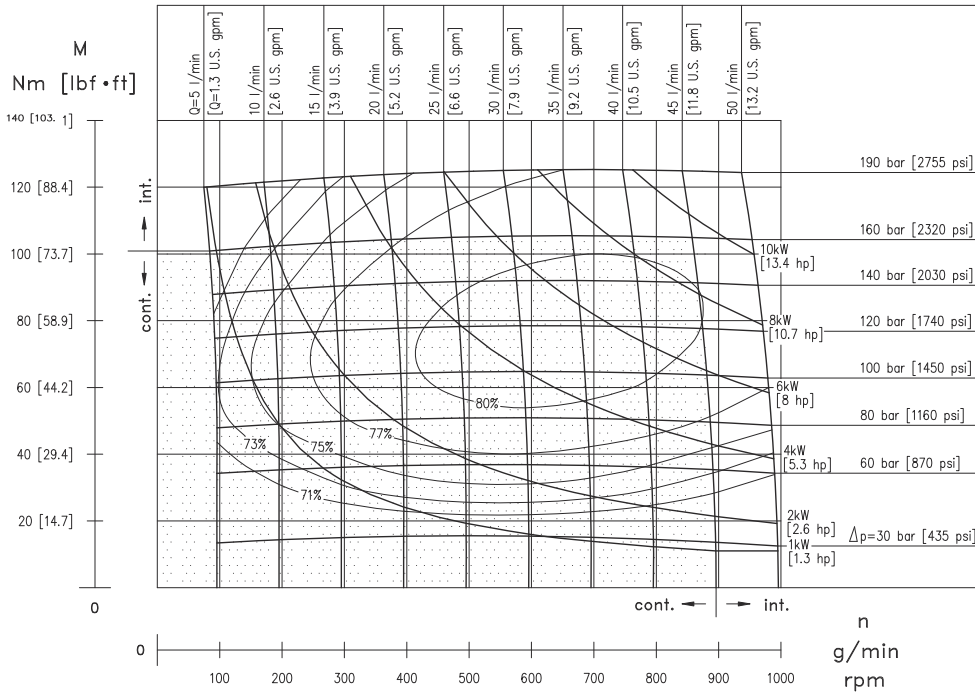

Exceeding continuous pressure values or exceeding flow values indicated, must not occur simultaneously.

AR 80

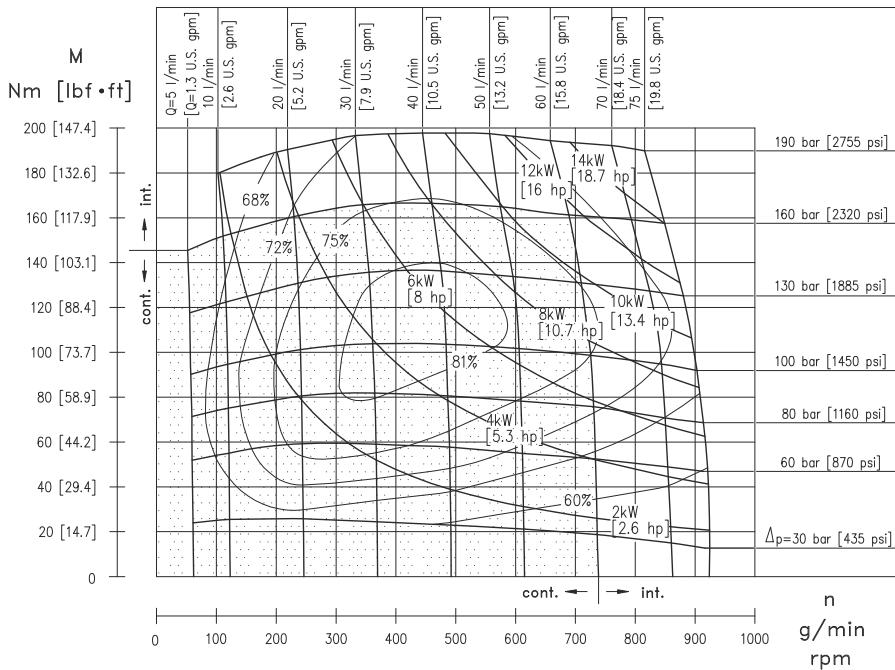

Exceeding continuous pressure values or exceeding flow values indicated, must not occur simultaneously.



AR 100

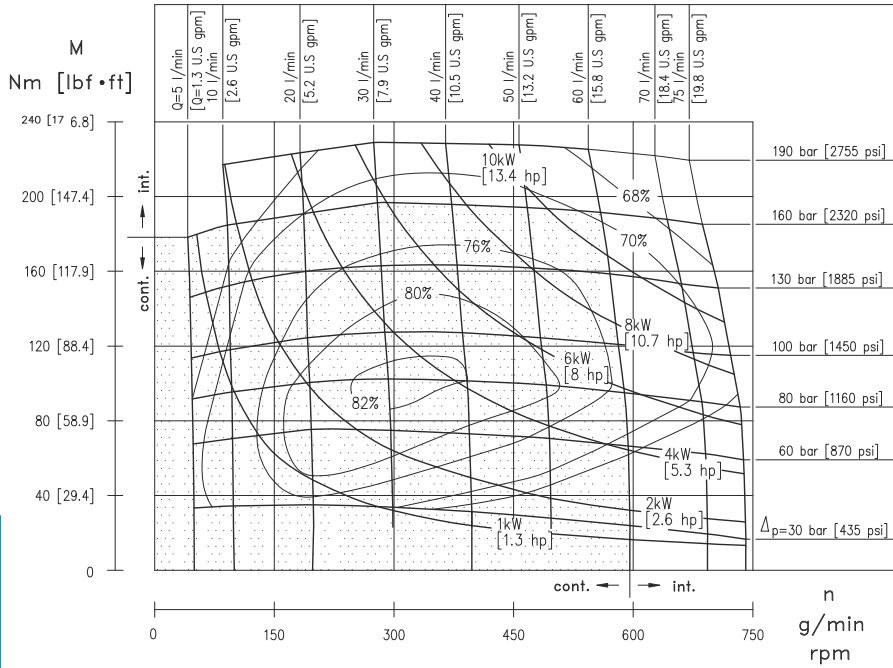

Exceeding continuous pressure values or exceeding flow values indicated, must not occur simultaneously.

AR 130

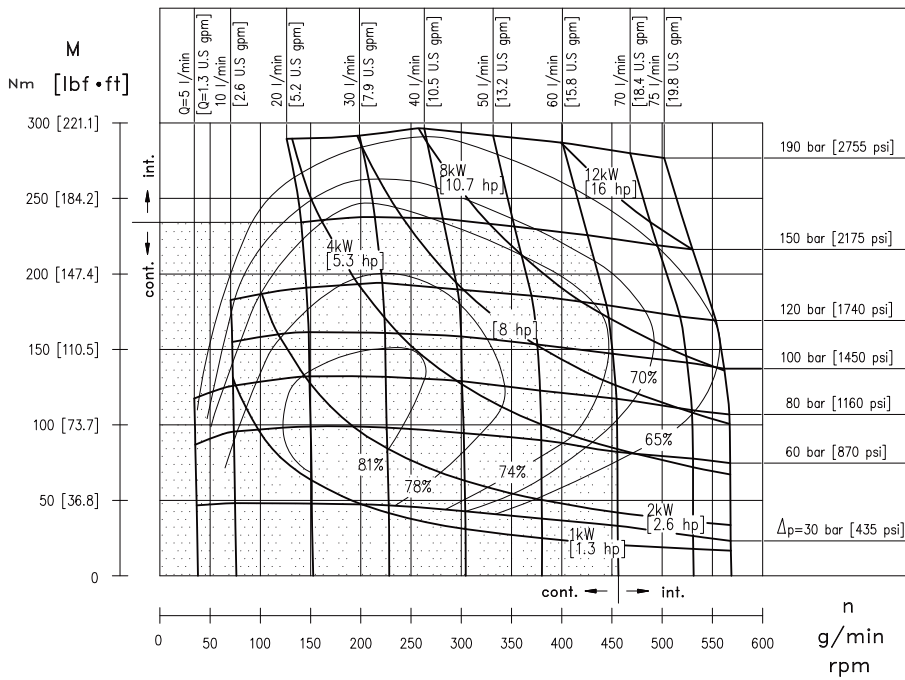

Exceeding continuous pressure values or exceeding flow values indicated, must not occur simultaneously.

AR 160

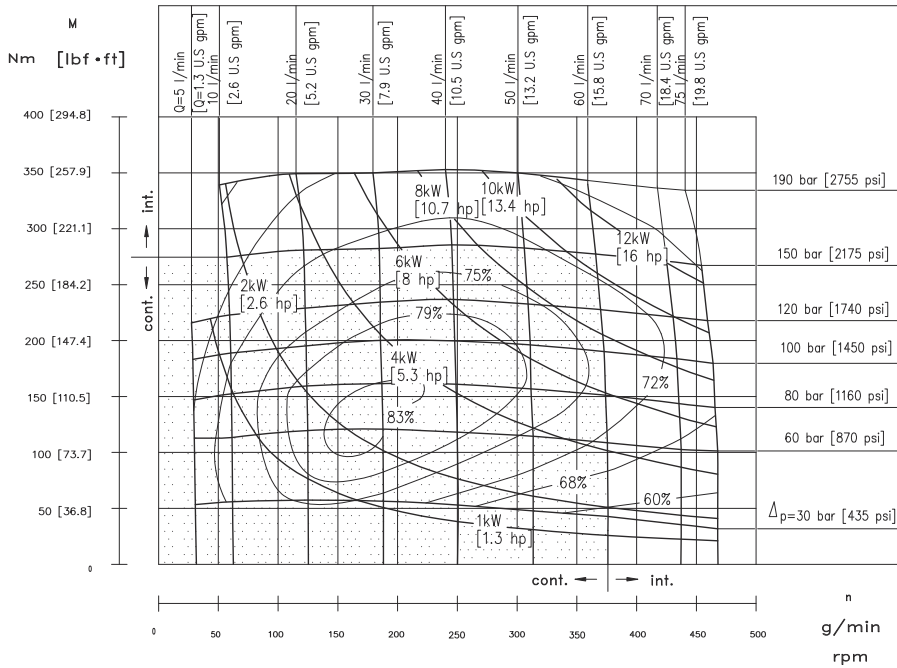

Exceeding continuous pressure values or exceeding flow values indicated, must not occur simultaneously.

AR 200

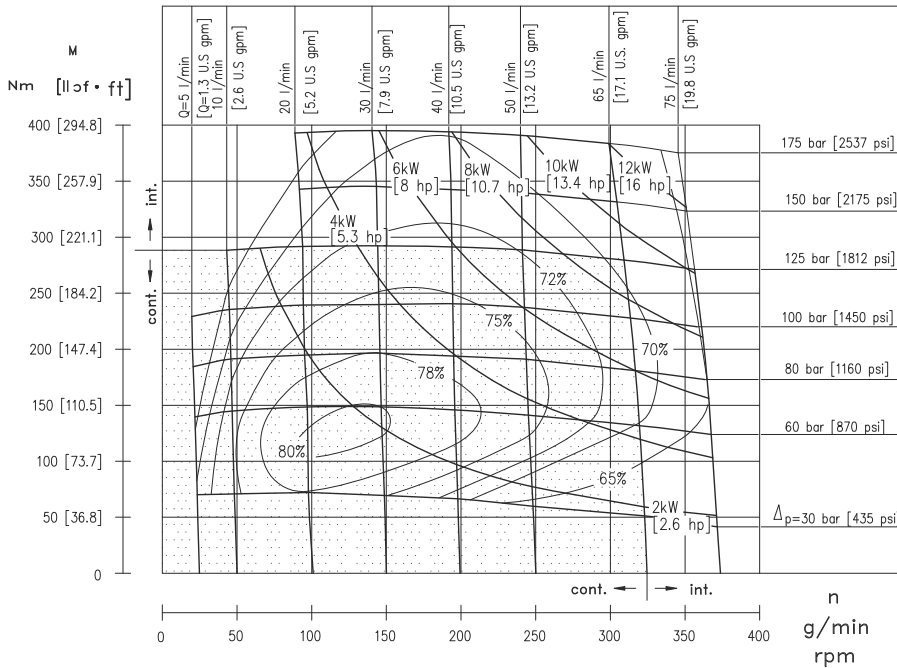

Exceeding continuous pressure values or exceeding flow values indicated, must not occur simultaneously.

Click **i** button to return to main index

Click **DANA** button to return to section index



AR 250

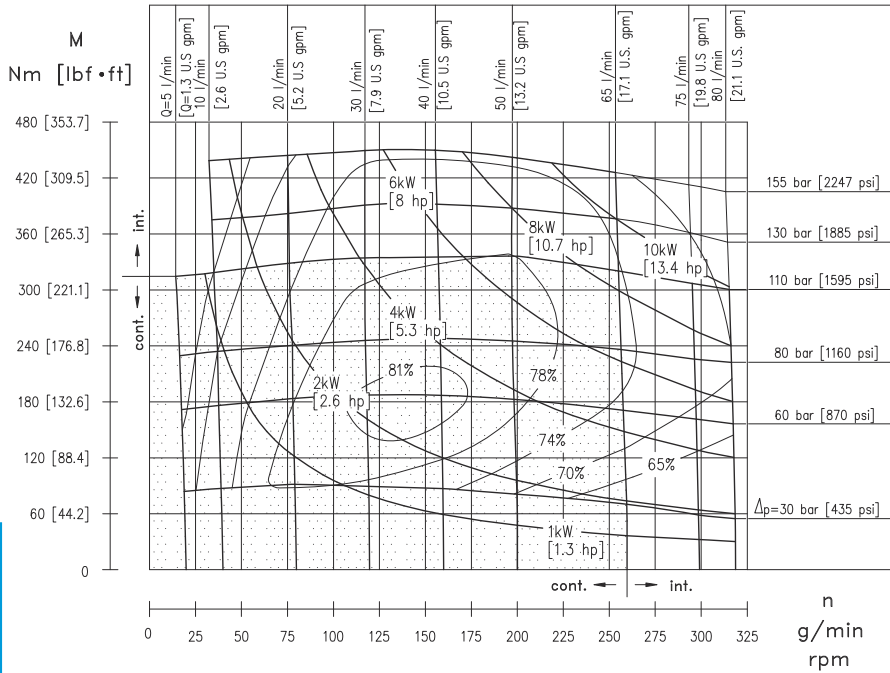

Exceeding continuous pressure values or exceeding flow values indicated, must not occur simultaneously.

AR 315

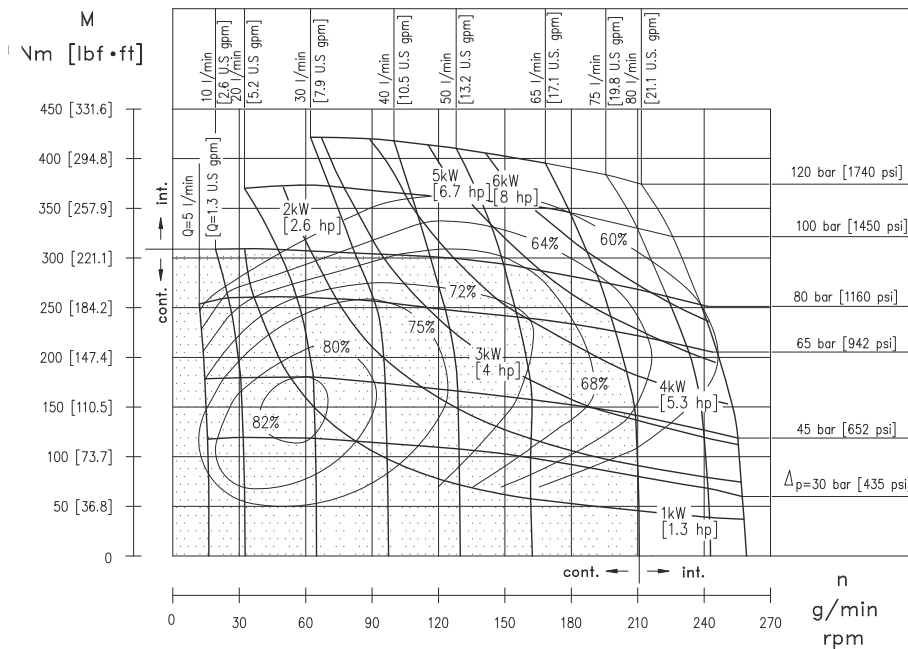

Exceeding continuous pressure values or exceeding flow values indicated, must not occur simultaneously.

AR 400

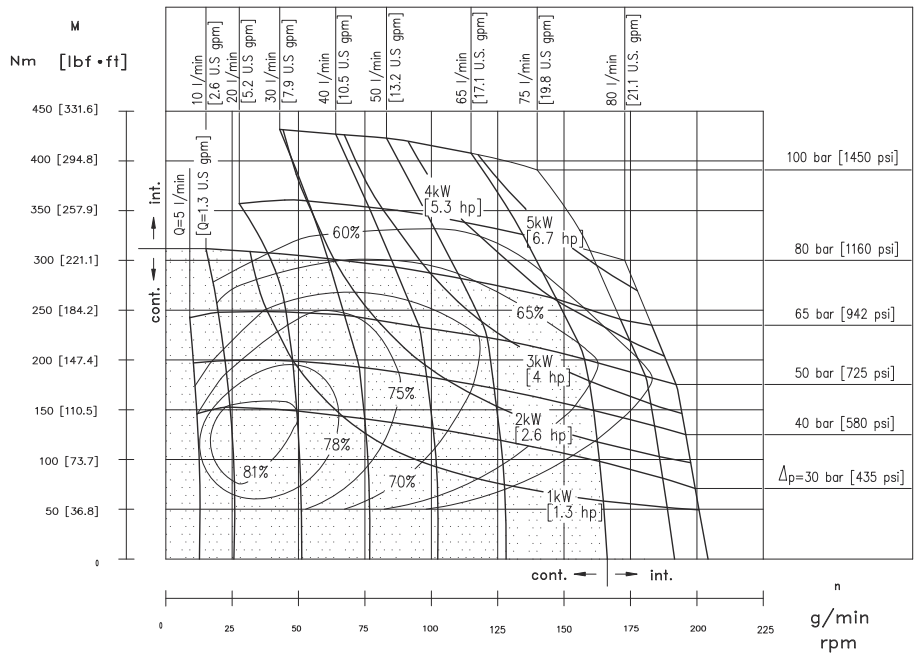

Exceeding continuous pressure values or exceeding flow values indicated, must not occur simultaneously.



Max. Pressure

	Motor	Displacement																																
		50			80			100			130			160			200			250			315			400								
		0	100	>	0	100	>	0	100	>	0	100	>	0	100	>	0	100	>	0	100	>	0	100	>	0	100	>						
	Speed rpm	-	-	-	-	-	-	-	-	-	-	-	-	-	-	-	-	-	-	-	-	-	-	-	-	-	-	-						
		100	300	300	100	300	300	100	300	300	100	300	300	100	300	300	100	300	300	100	300	300	100	300	300	100	300	300	100	300	300			
Max cont. Return pressure without drain line (bar) Conversions: 75 bar = 1088 psi 55 bar = 798 psi 50 bar = 725 psi 25 bar = 363 psi 20 bar = 290 psi	ARS	75	50	25	75	50	25	75	50	25	75	50	25	75	50	25	75	50	25	75	50	25	75	50	25	75	50	25	75	50	25			
	ARSW	75	50	25	75	50	25	75	50	25	75	50	25	75	50	25	75	50	25	75	50	25	75	50	25	75	50	25	75	50	25			
	ARF	20			20			20			20			20			20			20			20			20								
	../FP ⁴⁾	-			-			-			-			-			-			-			-			-								
	../N ³⁾	20			20			20			20			20			20			20			20			20								
	../D ³⁾	75	50	25	75	50	25	75	50	25	75	50	25	75	50	25	75	50	25	75	50	25	75	50	25	75	50	25	75	50	25	75	50	25
	TAC	20			20			20			20			20			20			20			20			20								
	TAC-E ³⁾	20			20			20			20			20			20			20			20			20								
Max return pressure with drain line bar [psi]		140 [2030]			140 [2030]			140 [2030]			140 [2030]			140 [2030]			140 [2030]			140 [2030]			140 [2030]			140 [2030]								
Min starting torque N [lbf]	Cont.	62 [46]			120 [88]			150 [111]			187 [138]			242 [178]			282 [208]			310 [228]			269 [198]			286 [211]								
	Int. ¹⁾	70 [51.6]			139 [102]			172 [127]			230 [170]			294 [217]			390 [287]			415 [306]			397 [293]			413 [304]								

AR

- 1) Intermittent duty must not exceed 10% each minute.
- 2) Peak duty must not exceed 1% each minute.
- 3) The back up pressure must be lower between the motor and the motor version considered.
- 4) In order to eliminate overheating it is necessary to use the drain port.

Max. Permissible Shaft Seal Pressure

ARS Motor are supplied in standard seal version (Standard chart) or in HPS seal version (HPS chart). For pressure and speeds not showed in the curve below, please contact Dana SamHydraulik.

N.B.: Tachometer and Brake versions is not available with HPS seals.

STANDARD

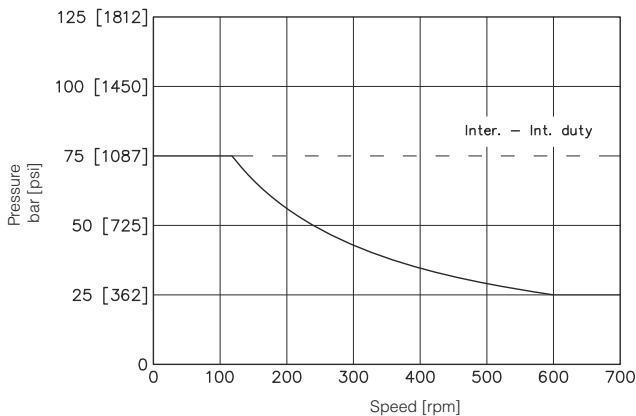

HPS

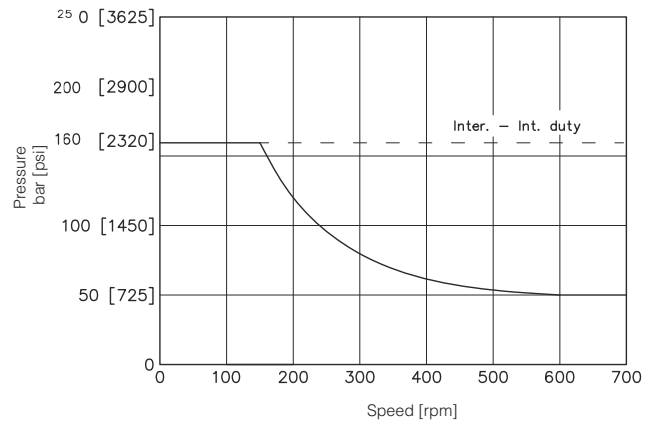

Click **DANA** button to return to section index

Click **i** button to return to main index

Pressure Loss

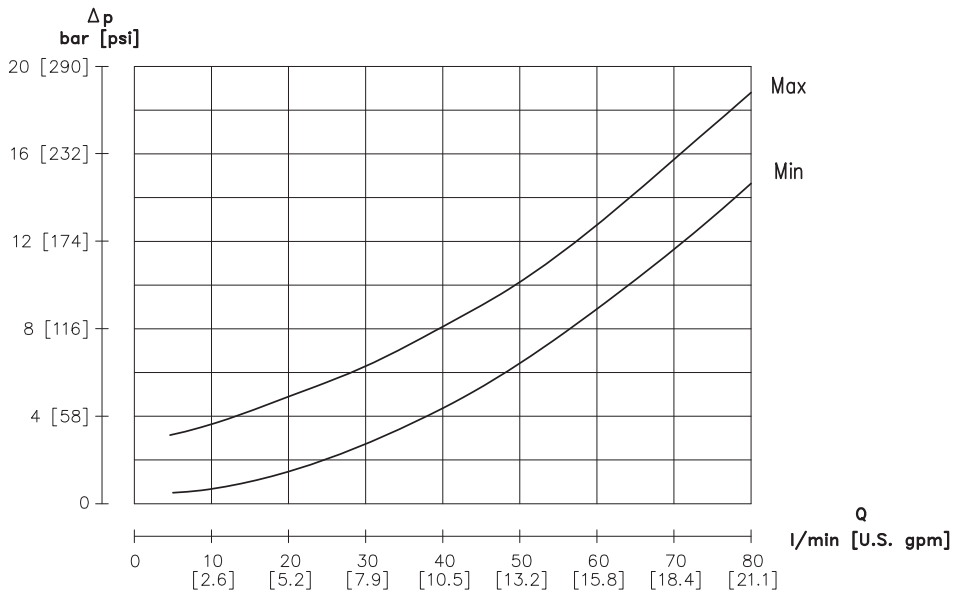

Low displacement motors have the tendency to operate near the “Max” curve, while high displacement ones have the opposite tendency.



Shaft Load

The load diagrams are valid for an average bearings life of 1.600 hrs at 200 r.p.m. with mineral base lubricating oil containing anti-wear additives (ref. ISO 281 (3.3) standard).

The "A" curve gives the maximum static load affordable by the bearings.
 The "B" curve gives the radial load top limit without axial loading.
 The "C" curve gives the radial load top limit with an axial load of 2000 N [450 lbf].
 The "D" curve gives the radial load top limit with an axial load of 6000 N [1350 lbf].
 The "E" curve gives the radial load top limit with an axial load of 8000 N [1800 lbf].

ARS

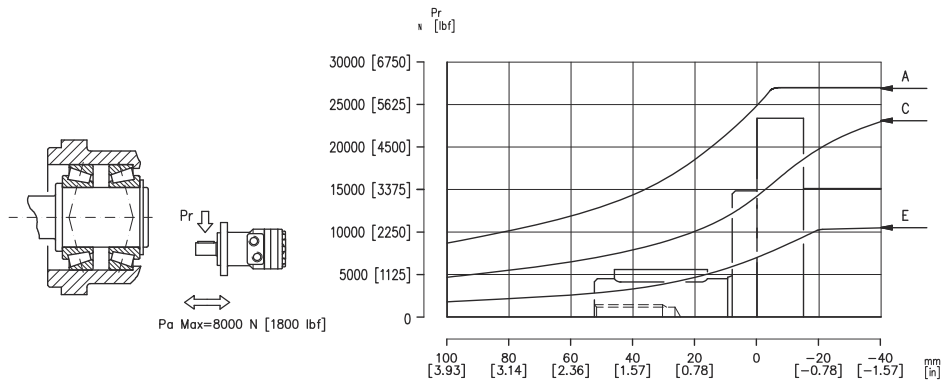

ARSW

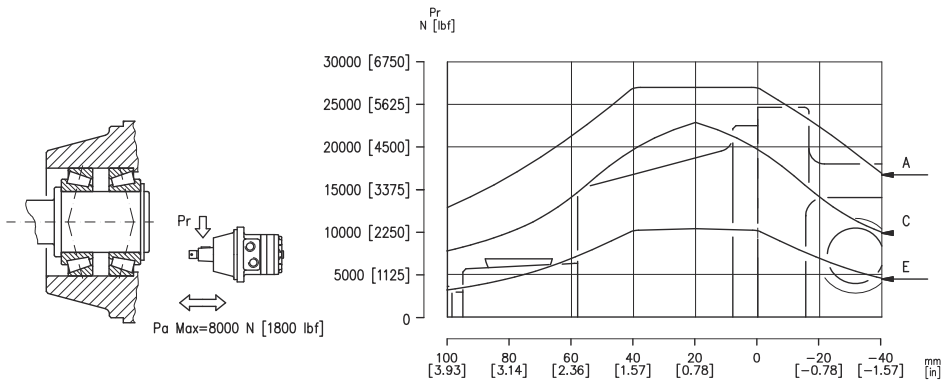

ARF

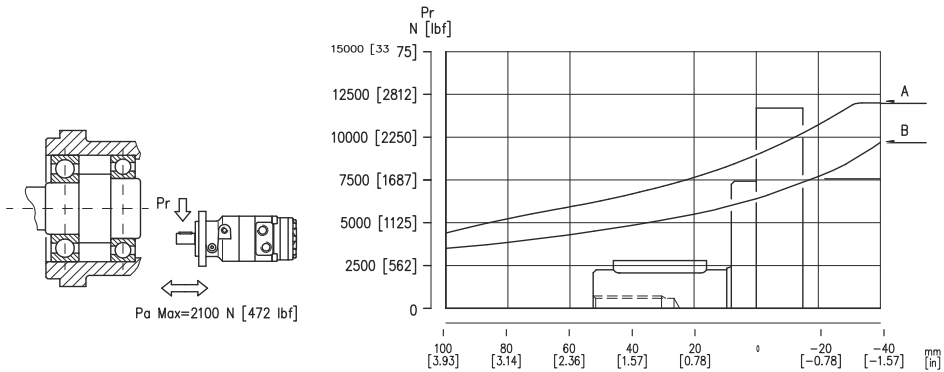

The following alphanumeric digits system has been developed to identify all of the configuration options for the AR motors. Use the model code below to specify the desired features. All alphanumeric digits system of the code must be present when ordering.

We recommend to carefully read the catalogue before filling the ordering code.

1	2	3	4	5
Series	Displacement	Mounting flange	Shaft end	Option
ARS	160	DR	C32	HPS

1	Series	
ARS	Orbital motor	
ARSW	Orbital motor	
ARF	Orbital motor	

2	Displacement	
050	50 cm ³ /giro [3.05 in ³ /rev]	
080	80 cm ³ /giro [4.88 in ³ /rev]	
100	100 cm ³ /giro [6.10 in ³ /rev]	
130	130 cm ³ /giro [7.93 in ³ /rev]	
160	160 cm ³ /giro [9.76 in ³ /rev]	
200	200 cm ³ /giro [12.20 in ³ /rev]	
250	250 cm ³ /giro [15.25 in ³ /rev]	
315	315 cm ³ /giro [19.21 in ³ /rev]	
400	400 cm ³ /giro [24.40 in ³ /rev]	

3	Mounting Flange		Series		
			ARS	ARSW	ARF
N	2 bolts		-	-	●
D	4 bolts		●	●	-

4	Shaft end		Series		
			ARS	ARSW	ARF
C25	Parallel keyed Ø25 mm [0.984 in]		●	●	●
C32	Parallel keyed Ø32 mm [1.259 in]		●	●	-
S32	Splined 14T 12/24 DP		●	●	-
SD25	Splined 1" 6B Tooth		●	●	-
CN32	Tapered		●	●	-

5	Option		Series		
			ARS	ARSW	ARF
HPS	High Pressure Seal		●	-	-
FP	Brake-motor		●	●	-
/N	Dual shaft oval flange		●	-	●
/D	Dual shaft square flange		●	-	●
TAC	Rev-counter connection		●	-	●
TAC-E	Electronic tachometer		●	-	●

● Available
- Not Available

Click **i** button to return to main index

Click **DANA** button to return to section index



- 1
- 2
- 3
- 4
- 5

ARS D C32

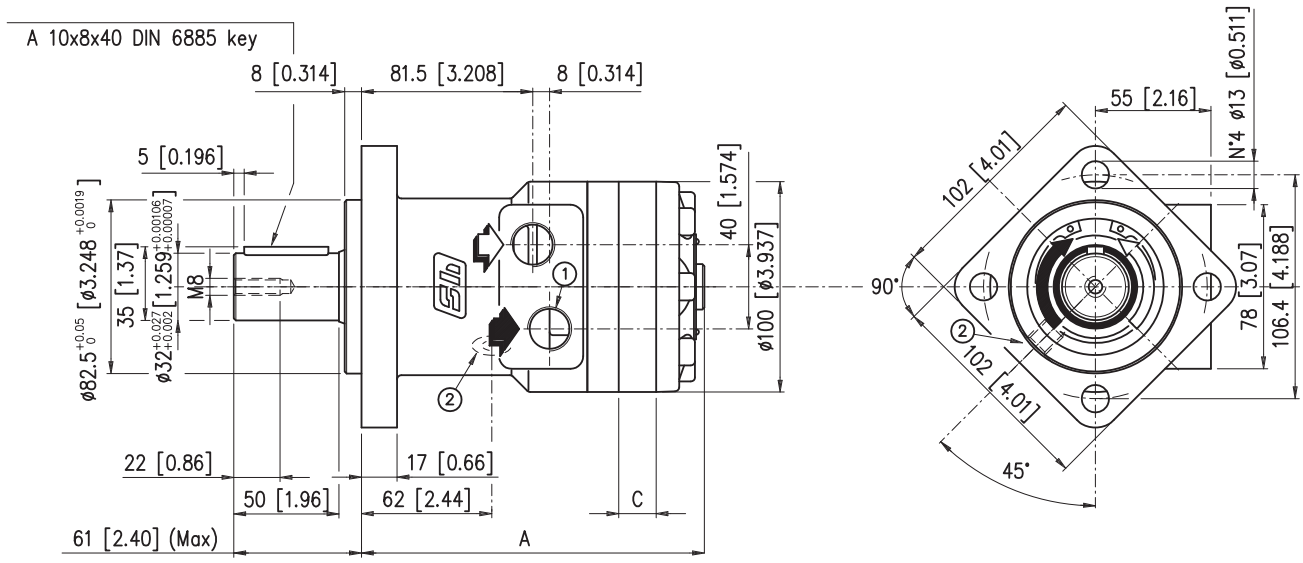

- ① No. 2 1/2 G (BSPP) main ports thread depth 18mm [0.70 in]
- ② 1/4 G (BSPP) drain motor depth 12 mm [0.472 in]

		ARS 50	ARS 80	ARS 100	ARS 130	ARS 160	ARS 200	ARS 250	ARS 315	ARS 400
A	mm [in]	152.5 [6.00]	157.5 [6.20]	160.9 [6.33]	165.3 [6.50]	171.3 [6.74]	178.3 [7.01]	187 [7.36]	198.3 [7.80]	211.8 [8.33]
C	mm [in]	9 [0.354]	14 [0.551]	17.4 [0.68]	21.8 [0.85]	27.8 [1.09]	34.8 [1.37]	43.5 [1.71]	54.8 [2.15]	68.38 [2.69]
Weight	kg [lb]	7.5 [16.5]	7.7 [16.9]	7.9 [17.4]	8.2 [18]	8.4 [18.5]	8.8 [19.3]	9.2 [20.2]	9.7 [21.3]	10.4 [22.9]

- 1
- 2
- 3
- 4
- 5

ARSW D

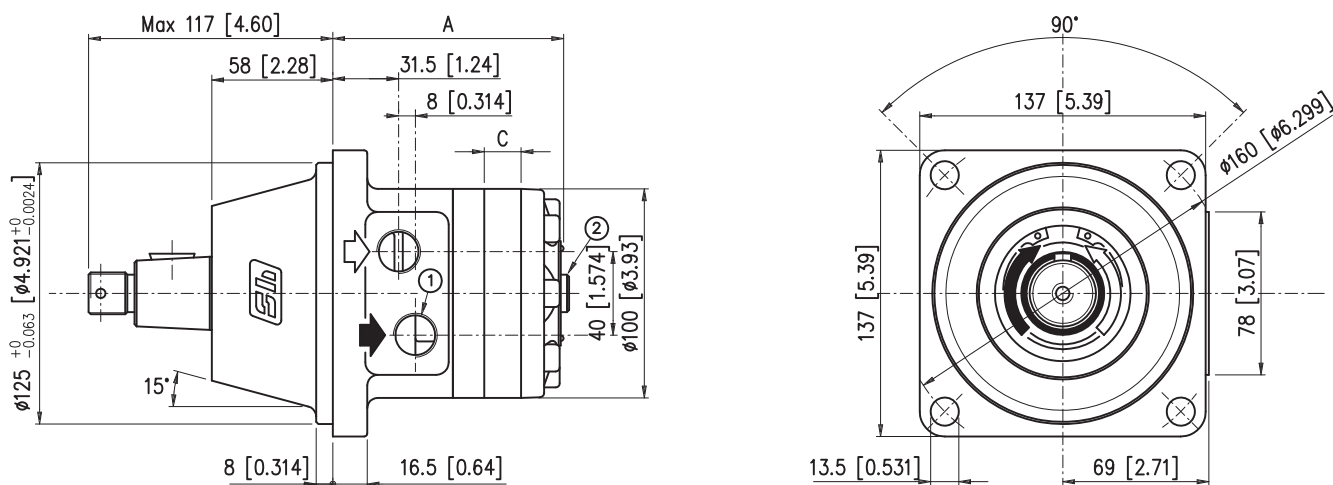

- ① No. 2 1/2 G (BSPP) main ports thread depth 18mm [0.70 in]
- ② 1/4 G (BSPP) drain motor depth 12 mm [0.472 in]

AR

		ARSW 50	ARSW 80	ARSW 100	ARSW 130	ARSW 160	ARSW 200	ARSW 250	ARSW 315	ARSW 400
A	mm [in]	102.5 [4.03]	107.5 [4.23]	110.9 [4.36]	115.3 [4.53]	121.3 [4.77]	128.3 [5.05]	137 [5.39]	148.3 [5.83]	161.8 [6.37]
C	mm [in]	9 [0.354]	14 [0.551]	17.4 [0.68]	21.8 [0.85]	27.8 [1.09]	34.8 [1.37]	43.5 [1.71]	54.8 [2.15]	68.38 [2.69]
Weight	kg [lb]	9.8 [21.5]	10.1 [22.2]	10.3 [22.7]	10.5 [23.1]	10.8 [23.8]	11.2 [24.6]	16.1 [35.4]	12.1 [26.6]	12.8 [28.2]



- 1
- 2
- 3
- 4
- 5

ARF N

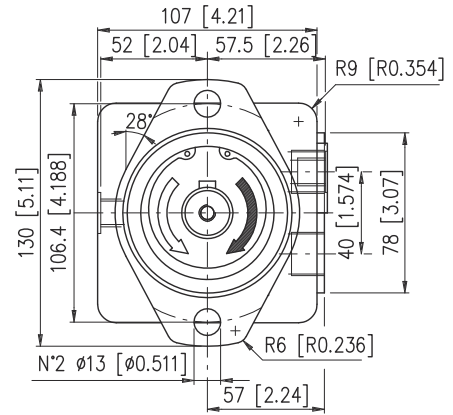
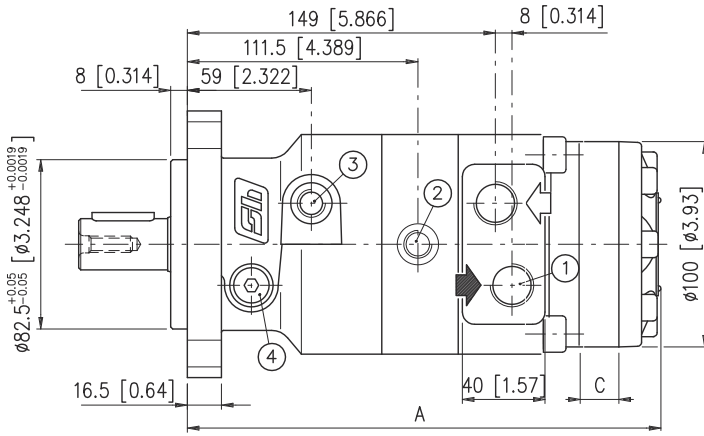

- ① No. 2 1/2 G (BSPP) main ports thread depth 18mm [0.70 in]
- ② 1/4 G (BSPP) drain motor depth 13 mm [0.511 in]
- ③ Brake releasing plug 1/4 G (BSPP) thread depth 13 mm [0.511 in]
- ④ N°2 brake filling and drain plugs 1/4 G (BSPP) thread depth 13 mm [0.511 in]

		ARF 50	ARF 80	ARF 100	ARF 130	ARF 160	ARF 200	ARF 250	ARF 315	ARF 400
A	mm [in]	220 [8.66]	225 [8.85]	228.4 [8.99]	232.8 [9.16]	238.8 [9.40]	245.8 [9.67]	254.5 [10.01]	265.8 [10.46]	279.3 [10.99]
C	mm [in]	9 [0.354]	14 [0.551]	17.4 [0.68]	21.8 [0.85]	27.8 [1.09]	34.8 [1.37]	43.5 [1.71]	54.8 [2.15]	68.38 [2.69]
Weight	kg [lb]	13.5 [29.7]	13.8 [30.4]	14.1 [31]	14.3 [31.5]	14.6 [32.1]	15.1 [33.2]	15.8 [34.8]	16.3 [35.9]	16.9 [37.2]

1

2

3

4

5

ARS D C32 HPS

A 10x8x40 DIN 6885 key

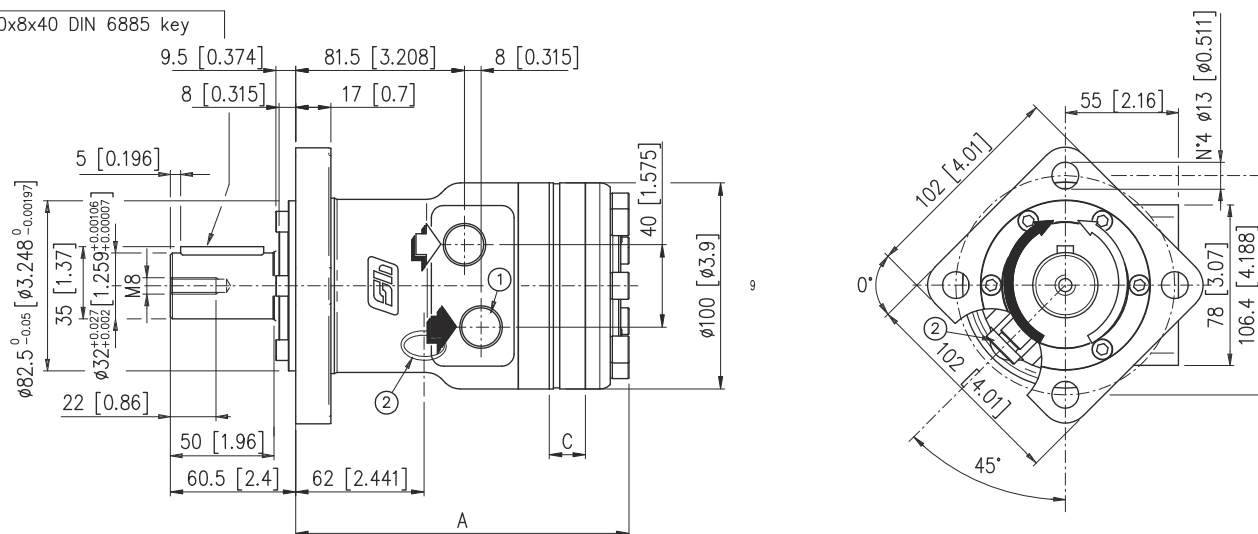

- ① No. 2 1/2 G (BSPP) main ports thread depth 18mm [0.70 in]
- ② 1/4 G (BSPP) drain motor depth 12 mm [0.472 in]

		ARS 50	ARS 80	ARS 100	ARS 130	ARS 160	ARS 200	ARS 250	ARS 315	ARS 400
A	mm [in]	152 [5.98]	157 [6.18]	161 [6.34]	165 [6.50]	171 [6.73]	178 [7.01]	187 [7.36]	198 [7.79]	212 [8.35]
C	mm [in]	9 [0.354]	14 [0.551]	17.4 [0.68]	21.8 [0.85]	27.8 [1.09]	34.8 [1.37]	43.5 [1.71]	54.8 [2.15]	68.38 [2.69]
Weight	kg [lb]	7.5 [16.5]	7.7 [16.9]	7.9 [17.4]	8.2 [18]	8.4 [18.5]	8.8 [19.3]	9.2 [20.2]	9.7 [21.3]	10.4 [22.9]

Click **i** button to return to main index

Click **DANA** button to return to section index



1

2

3

4

5

S32 Splined Shaft

Max Torque Continuous 768 Nm [566 lbf-ft]

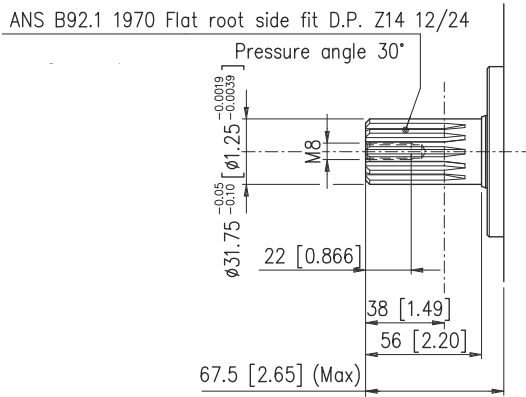

C25 Cylindrical Shaft

Max Torque Continuous 300 Nm [221.1 lbf-ft]

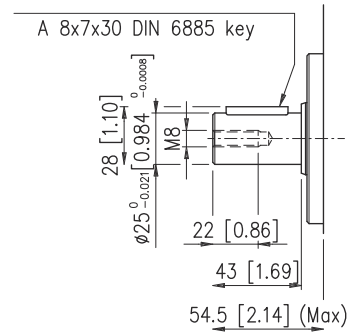

CN32 Tapered Shaft

Max Torque Continuous 860 Nm [633.8 lbf-ft]

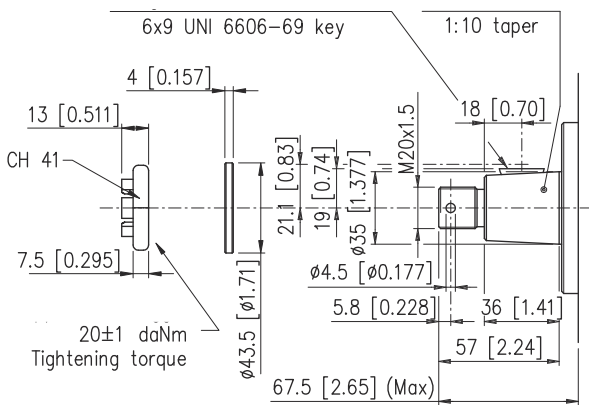

D25 Splined Shaft

Max Torque Continuous 360 Nm [225.3 lbf-ft]

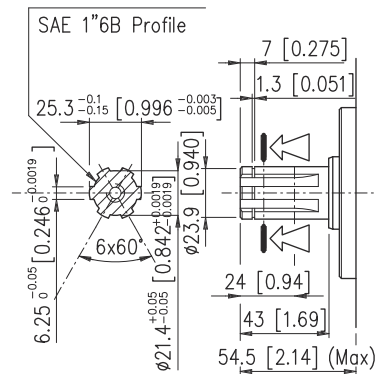

C32 Cylindrical Shaft

Max Torque Continuous 768 Nm [566 lbf-ft]

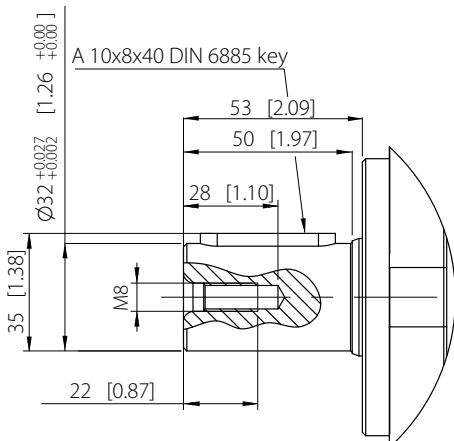

ARS D FP Brake Motor

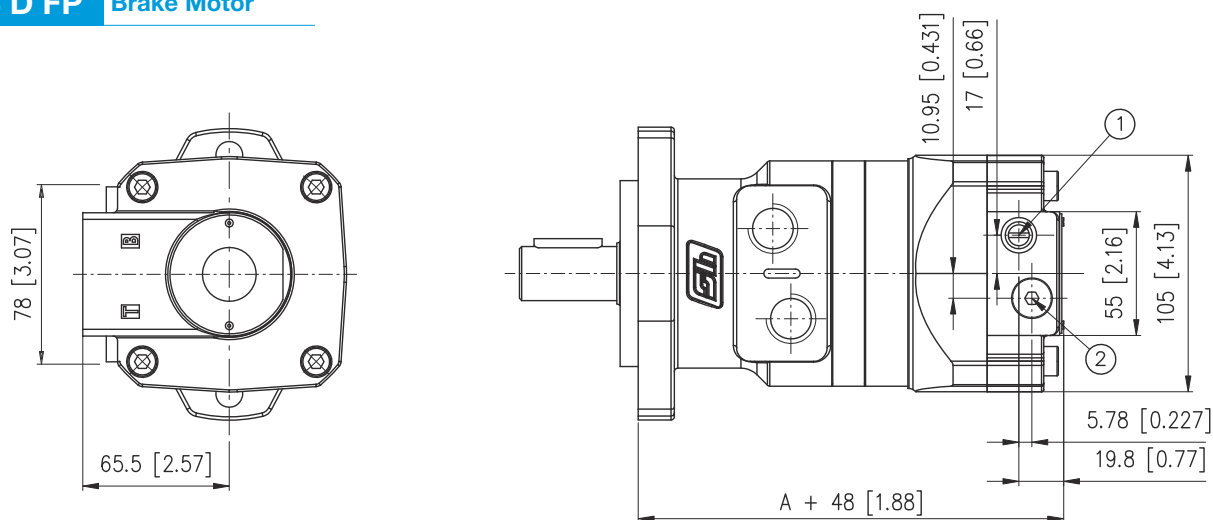

- ① 1/4 G (BSPP) brake releasing port; thread depth 13 mm [0.511 in]
 ② 1/4 G (BSPP) drain port thread depth 13 mm [0.511 in]

Brake available on following engines: ARS - ARSW
 "A" Dimension is related to motor length without FP brake

Brake Feature

The ARF and FP motors have a multi-plate disc brake built in, which is hydraulically released. This mechanical type brake has springs that push together the plates, which are mounted side by side, so that a static braking action is obtained. Whenever an hydraulic pressure acts on the piston, the brake is released. The so called "negative brake" is suitable for duties like parking or safety brakes and/or whenever a static braking action is required.

A dynamic braking action must be obtained using the hydraulic circuit. If a motor is to be used for dynamic braking (which is unadvisable) please contact Dana SamHydraulik Engineering Service first.

High rotation speed and/or vertical position use of the motor might cause discs to overheat, particularly in FP brakes, and consequential malfunctioning. In this case, please contact Dana SamHydraulik Engineering Service.

Brake features:	ARF (*)
Mimimum releare pressure	22 bar [319 psi]
Complete brake release press.	27 bar [391.5 psi]
Max. pressure	200 bar [2900 psi]
Max static torque	350 Nm [257.9 lbf·ft]

Brake features:	FP
Mimimum releare pressure	22 bar [319 psi]
Complete brake release press.	25 bar [362.5 psi]
Max. pressure	160 bar [2320 psi]
Max static torque	370 Nm [272.6 lbf·ft]
Max motor speed	350 rpm

(*) : The ARF motor has a separate brake chamber which must be filled with 80 cm³ of hydraulic oil.

- The FP hydraulic motors must always have the drain port (on casing) directly connected with tank. This improves oil cooling, which is important to avoid brake overheating.
- It is advisable to use heat and wear resistant hydraulic oils in ARF type motors: viscosity grade ISO VG 32; viscosity index 95
- If open circuit layout is needed, it is advisable to use a flow control valve on brake piston ports, in order to avoid dynamic braking.

Common application layouts on following page.

Click **i** button to return to main index

Click **DANA** button to return to section index



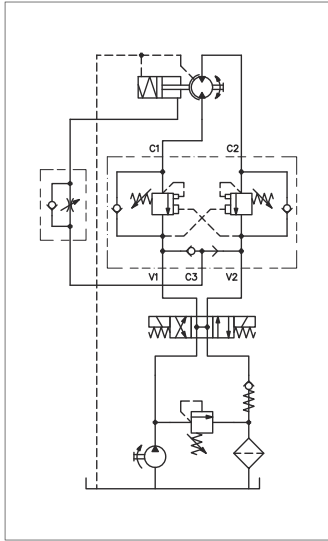

OPEN LOOP SYSTEM , ONE BRAKE-MOTOR, BI-DIRECTIONAL TURNING AND AUTOMATIC BRAKE OPERATION.

This configuration is typically that of a slew drive (cranes, excavators, aerial platforms, derricks, etc.).
 When the pump delivers oil to the motor the consequent generation of pressure will operate the shuttle valve and activate the brake line, thus disengaging the brake itself.
 When the oil delivery is shut off to stop the machine, a double overcentre valve will slow down the rotating mass to an almost complete stop when the static brake will engage.

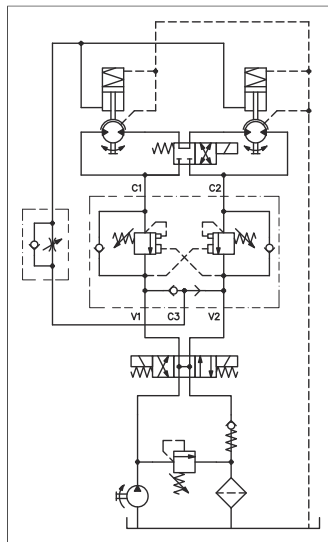

OPEN LOOP SYSTEM , TWO BRAKEMOTORS, BI-DIRECTIONAL TURNING AND AUTOMATIC BRAKES OPERATION.

This is a typical layout of the travelling system of a mobile machine (aerial platforms, etc.).
 Fluid under pressure disengages the brakes and starts the two motors; a commutation device will connect the two motors either in series or parallel mode in order to have either speed or torque as main performance.
 The double overcentre valve will steadily slow down the machine and bring it to an almost complete stop when the brakes will engage.

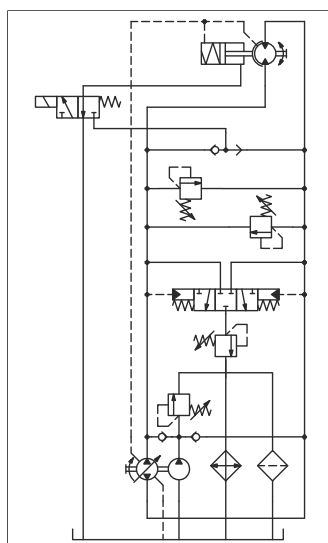

CLOSED LOOP SYSTEM, ONE BRAKEMOTOR, BI-DIRECTIONAL TURNING, AUTOMATIC BRAKE OPERATION AND VARIABLE PUMP.

A very typical system for sweepers.
 The pump delivers a variable flow of oil to the motor hence the machine can travel at variable speed.
 The brake is disengaged by the deliver of flow from the shuttle valve via the electrovalve (top, right) that will also release the fluid under pressure from inside the brake piston chamber when the motor stops and the brake engages.

1

2

3

4

5

.../N..

Dual shaft oval flange

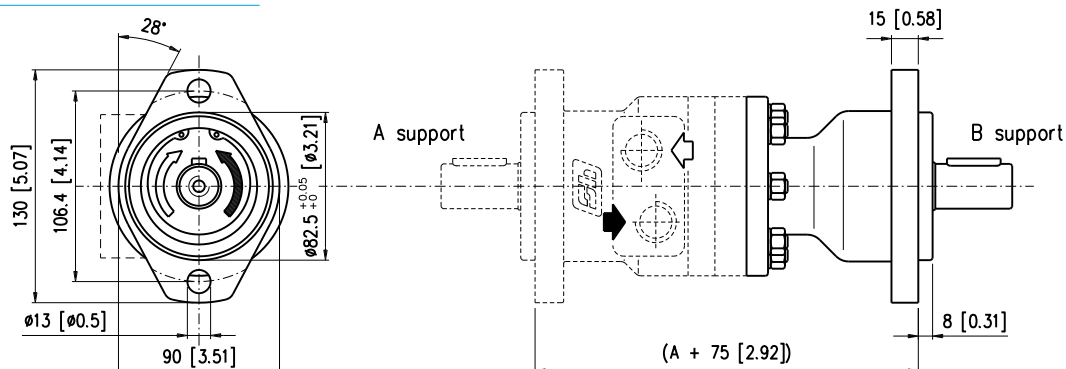

“A” dimension is related to motor length without double-shaft .../N..

Available on following motors: ARS, ARF

Available shafts for B support: C25, SD25, S25

.../D..

Dual shaft square flange

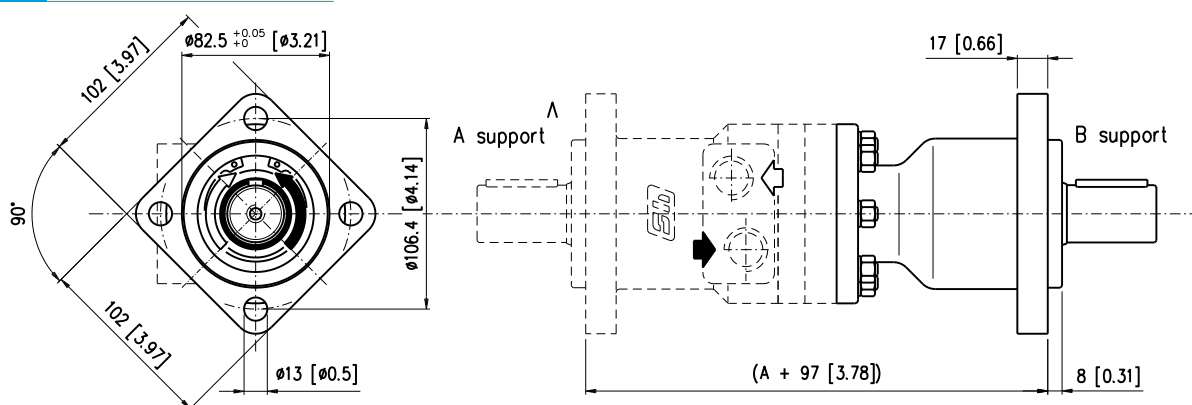

“A” dimension is related to motor length without double-shaft .../D..

Available on following motors: ARS, ARF

Available shafts for B support: C25, SD25, C32, S32, CN32, C31.75

Max. trasmission torque from double-shaft motors

Motor	Displacement cm ³ /rev [in ³ /rev]	Max. torque		Max. torque A shaft Nm [lbf ft]	Max. torque B shaft Nm [lbf-ft]	Supp.../N weight kg [lbs]	Supp.../D weight kg [lbs]
		Cont	Int				
AR 50	51.6 [3.14]	Cont	100 [74]	85 [63] 95 [70]	45 [33] 50 [37]	3.5 [7.71]	4.5 [9.92]
		Int	115 [85]				
AR 80	80.4 [4.9]	Cont	170 [125]	115 [85] 130 [96]	115 [85] 130 [96]	3.5 [7.71]	4.5 [9.92]
		Int	200 [147]				
AR 100	100 [6.1]	Cont	200 [147]	125 [92] 140 [103]	125 [92] 140 [103]	3.5 [7.71]	4.5 [9.92]
		Int	230 [170]				
AR 130	125.7 [7.66]	Cont	240 [177]	200 [147] 230 [170]	200 [147] 230 [170]	3.5 [7.71]	4.5 [9.92]
		Int	300 [221]				
AR 160	160 [9.76]	Cont	290 [214]	200 [147] 230 [170]	200 [147] 230 [170]	3.5 [7.71]	4.5 [9.92]
		Int	355 [262]				
AR 200	200 [12.2]	Cont	295 [217]	200 [147] 230 [170]	200 [147] 230 [170]	3.5 [7.71]	4.5 [9.92]
		Int	395 [291]				
AR 250	250 [15.2]	Cont	335 [247]	335 [247] 455 [335]	200 [147] 230 [170]	3.5 [7.71]	4.5 [9.92]
		Int	455 [335]				
AR 315	314.5 [19.1]	Cont	310 [228]	310 [228] 425 [313]	310 [228] 425 [313]	3.5 [7.71]	4.5 [9.92]
		Int	425 [313]				
AR 400	393 [23.9]	Cont	315 [232]	315 [232] 435 [321]	315 [232] 435 [321]	3.5 [7.71]	4.5 [9.92]
		Int	435 [321]				

Click **i** button to return to main index

Click **DANA** button to return to section index



1

2

3

4

5

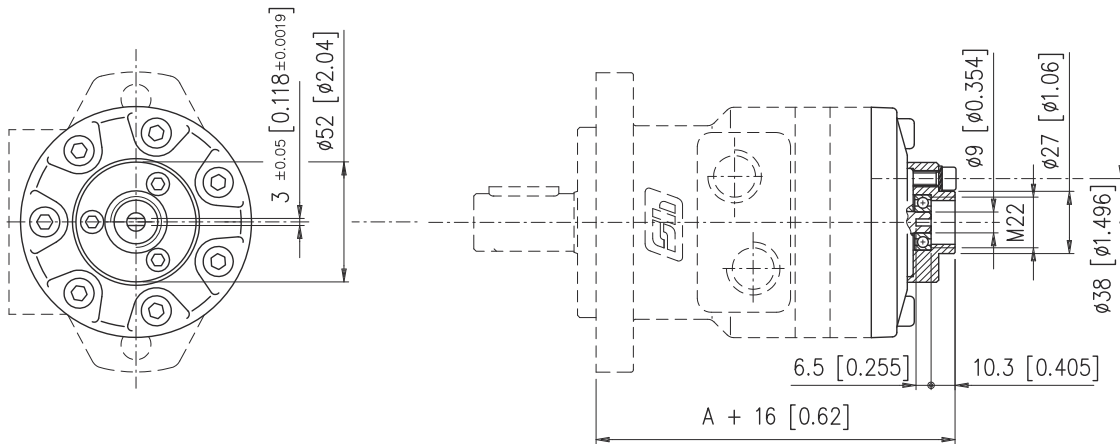
TAC* Rev-counter connection

“A” dimension is related to motor length without tacho.

NOTE:

Axial or radial load on tacho shaft must be avoided. Max torque on tacho shaft 1 Nm [0.73 lbf-ft].

WARNING:

The tacho shaft revolution speed is 6 times more than the motor one and opposite direction of rotation.

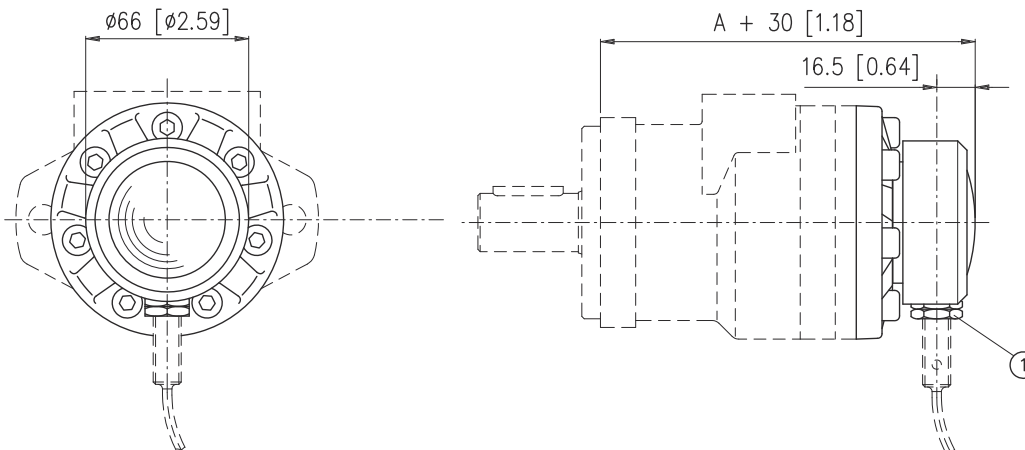
TAC-E* Electronic tachometer

① Sensor thread M8x1

“A” dimension is related to motor length without electronic tacho.

Number of pulses per revolution = 90

WARNING:

The electronic sensor is not supplied: if required, please state it clearly on order form.

Max case pressure admissible on the shaft seal with closed drain port: 20 bar [290 psi].

* Tachometer is not available on ARSW motor