

HYDRAULIC DISC BRAKES LB, LBS, LBV- Wet



APPLICATION

- » Heavy Duty machinery
- » Wheel drives
- » Material handling
- » Mining
- » Agricultural machines
- » Conveyors
- » Door openers and swing drives etc.



GENERAL

Fluid type	Mineral based- HLP(DIN 51524) or HM(ISO 6743/4)
Temperature range, °C [°F]	-40÷140 [-40÷284]
Viscosity range, mm²/s	20÷75 [98÷347]
Filtration	ISO code 20/16 (nominal filtration of 25 microns)
Maintenance	Changed after the first 50-100 h, then after every 500-1500 h.

CONTENTS

Hydraulic Disc Brake for MP, MR and MS Motors type LB/288	4÷5
Hydraulic Disc Brake for MSS and MSV type LBS(V)/289	6
Hydraulic Disc Brake for MSS and MSV type LBS(V)/290	7
Output Shafts for LBS(LBV)/289, 290	8
Specification data for LBS(LBV)/289, 290	8
Internal Spline data for .../289,290 and .../314,315.....	8
Load curve for LBS(LBV)/289, 290	9
Order code for LB/288,LBS(LBV)/289, 290	9
Hydraulic Disc Brake for MTS and MTV type LBS(LBV)/314	10
Hydraulic Disc Brake for MTS and MTV type LBS(LBV)/315	11
Specification data for LBS(LBV)/314, 315	12
Load curve for LBS(LBV)/314, 315	12
Output Shafts for LBS(LBV)/314, 315	13
Order code for LBS(LBV)/314, 315	13
Hydraulic Disc Brake for MVS type LBS/313	14
Load curve for LBS/313	14
Hydraulic Disc Brake for MVS type LBS/316	15
Load curve for LBS/316	15
Specification data for LBS/313, 316.....	16
Output Shafts for LBS/313, 316	16
Internal Spline data for LBS/313, 316	17
Order code for LBS/313, 316	17

LB, LBS

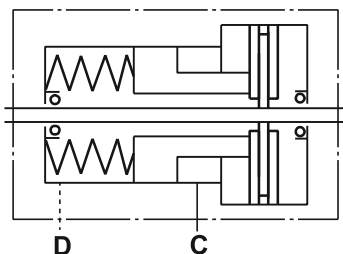

LBV

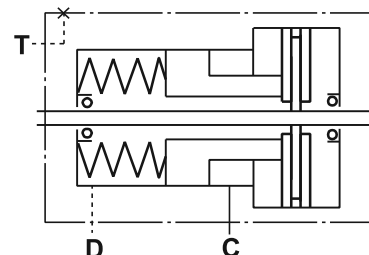

HYDRAULIC DISC BRAKE FOR FLANGE ATTACHMENT TO MP, MR AND MS HYDRAULIC MOTORS

TYPE LB/288

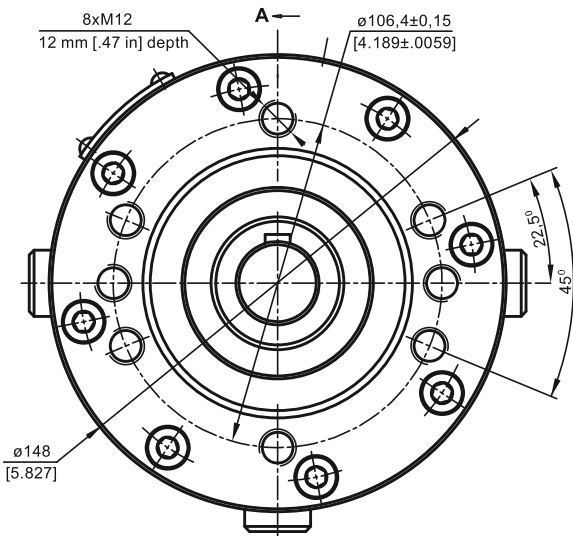
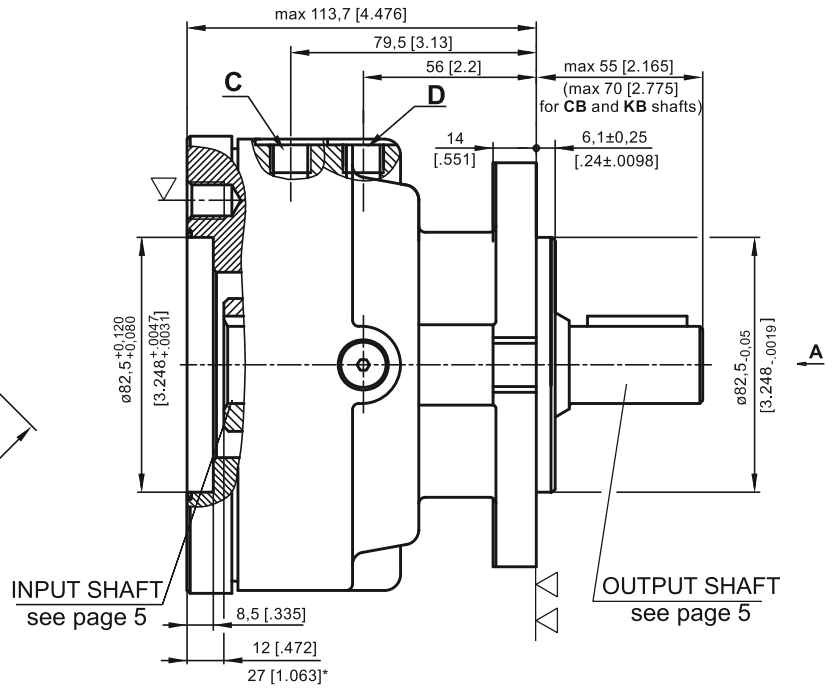
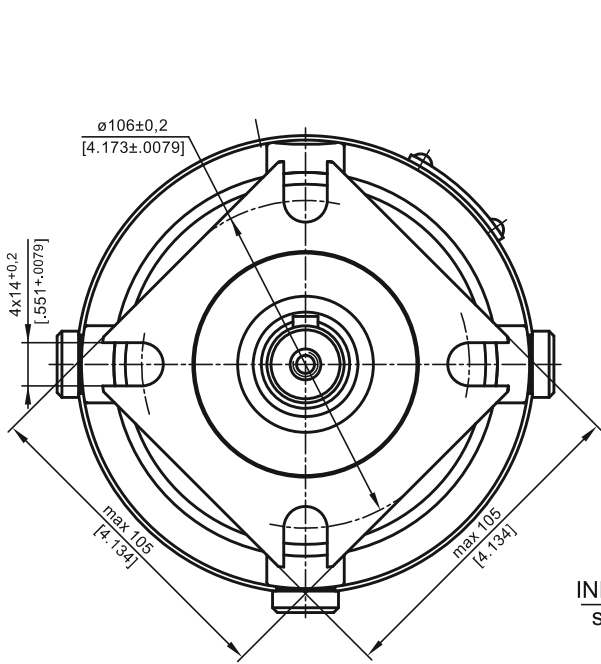

- ▽ - Place for attachment (tightening torque for screw M12x30 - 8.8 DIN 912 - 7 daNm [620 lb-in])
- ▽▽ - Place for attachment

- C:** Brake release Port - G $\frac{1}{4}$, 9 mm [0.35 in] depth
- D:** Drainage tap - G $\frac{1}{4}$, 9 mm [0.35 in] depth

* - For Input Shaft Hole Versions **SH** and **SB**.

LOAD CURVE

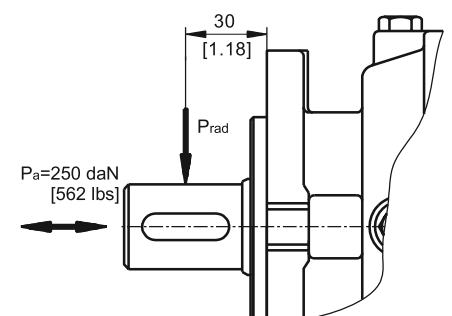
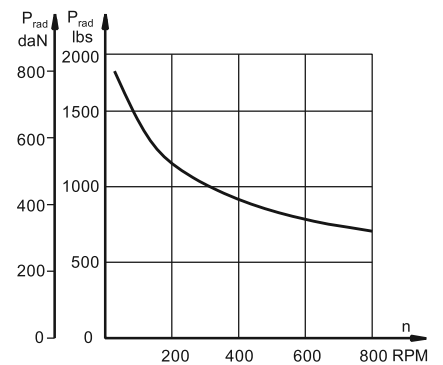

SPECIFICATION DATA

Description LB/288...	7	14	21	32	43	63
*Min. Static Torque, daNm [lb-in]	6-8 [531-708]	13-15 [1150-1327]	20-22 [1770-1947]	31-34 [2743-3009]	41-45 [3628-3982]	61-64 [5399-5665]
Opening Pressure, min bar [PSI]	4-5 [58-73]	8-9 [116-130]	12-13 [174-188]	18-20 [260-290]	24-26 [348-377]	38-39 [550-565]
max	300 [4350]					
Min. oil quantity for brake releasing, cm ³ [in ³]	7 - 8 [0.427 - 0.488]					
Oil volume, cm ³ [in ³]	50 - 120 [3.5 - 7.35]					
Max. Pressure in drain space, bar [PSI]	0,5 [7.25]					
Weight, kg [lb]	9 [19.8]					

*Static torque is obtained at working pressure - 0 bar [0 PSI].

INPUT SHAFT HOLES

C

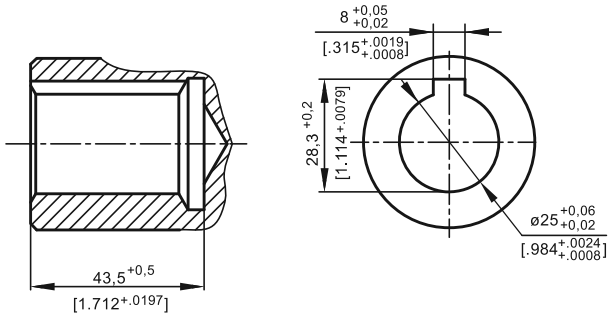

CO

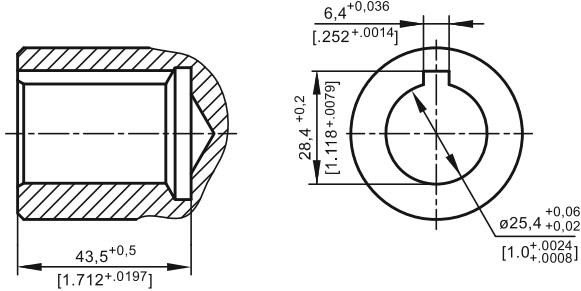

SH

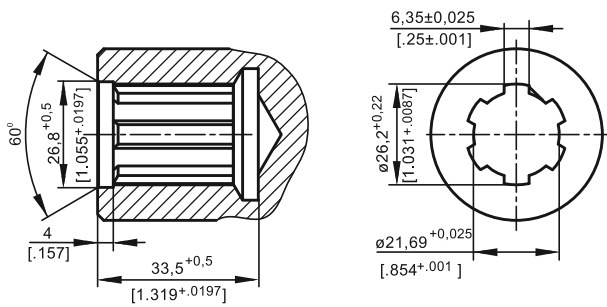

SB

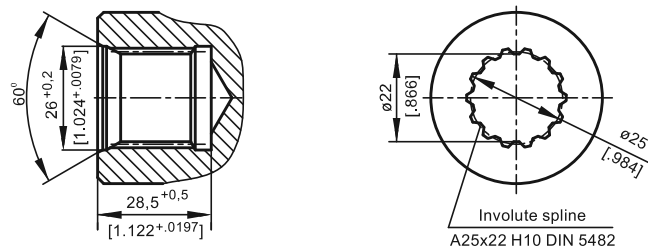

CB

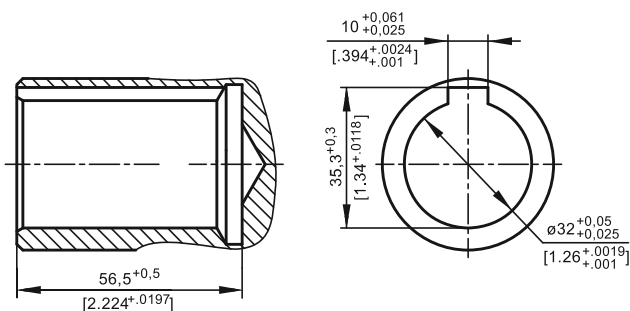

OUTPUT SHAFT EXTENSIONS

C - $\phi 25$ straight, Parallel key A8x7x32 DIN 6885
Max. Torque 34 daNm [3010 lb-in]

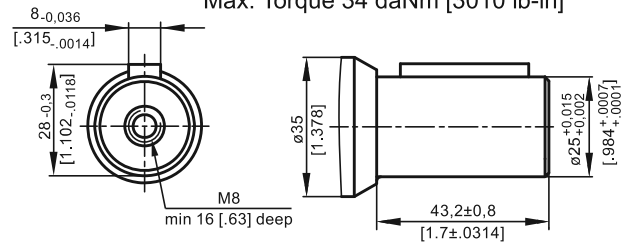

CO - $\phi 1"$ straight, Parallel key 1/4"x1/4"x1/4" BS46
Max. Torque 34 daNm [3010 lb-in]

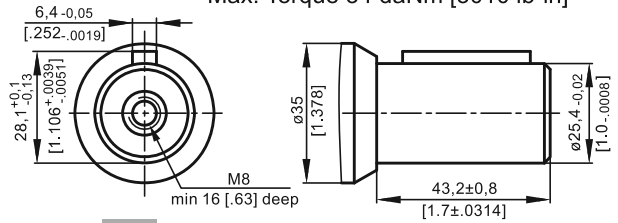

SH - splined, BS 2059 (SAE 6B)
Max. Torque 40 daNm [3540 lb-in]

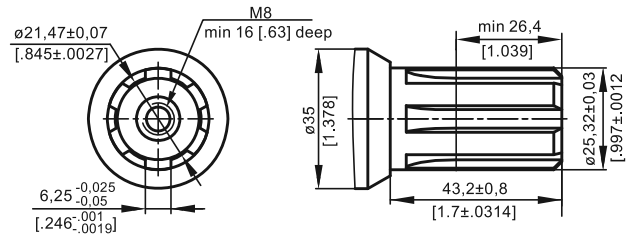

SA - splined, B25x22h9 DIN 5482
Max. Torque 40 daNm [3540 lb-in]

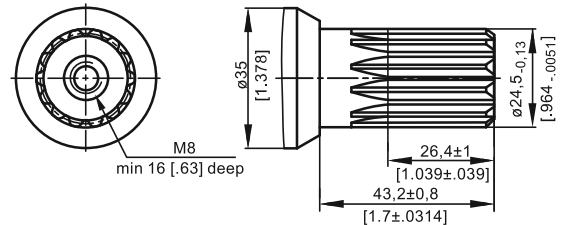

CB - $\phi 32$ straight, Parallel key A10x8x45 DIN 6885
Max. Torque 77 daNm [6815 lb-in]

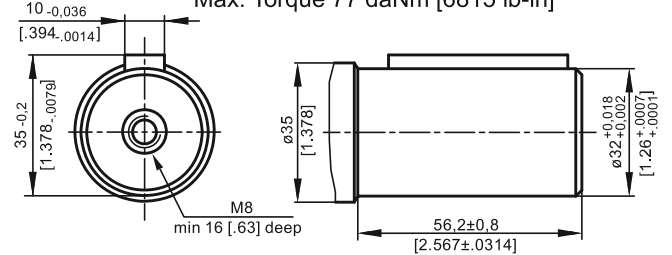

KB - tapered 1:10, Parallel key B6x6x20 DIN 6885
Max. Torque 95 daNm [8400 lb-in]

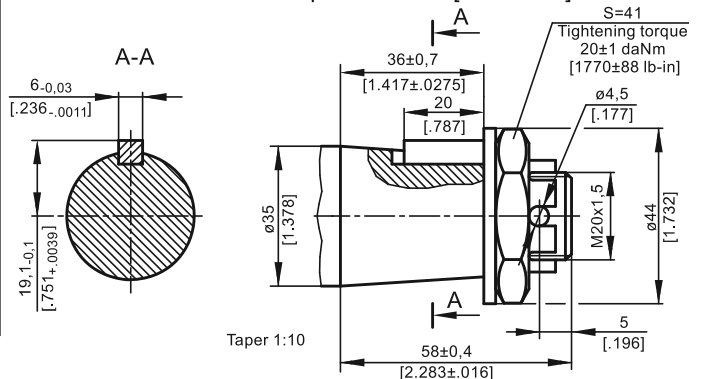

**HYDRAULIC DISC BRAKE FOR FLANGE ATTACHMENT
TO MSS AND MSV HYDRAULIC MOTORS**

TYPE LBS/289

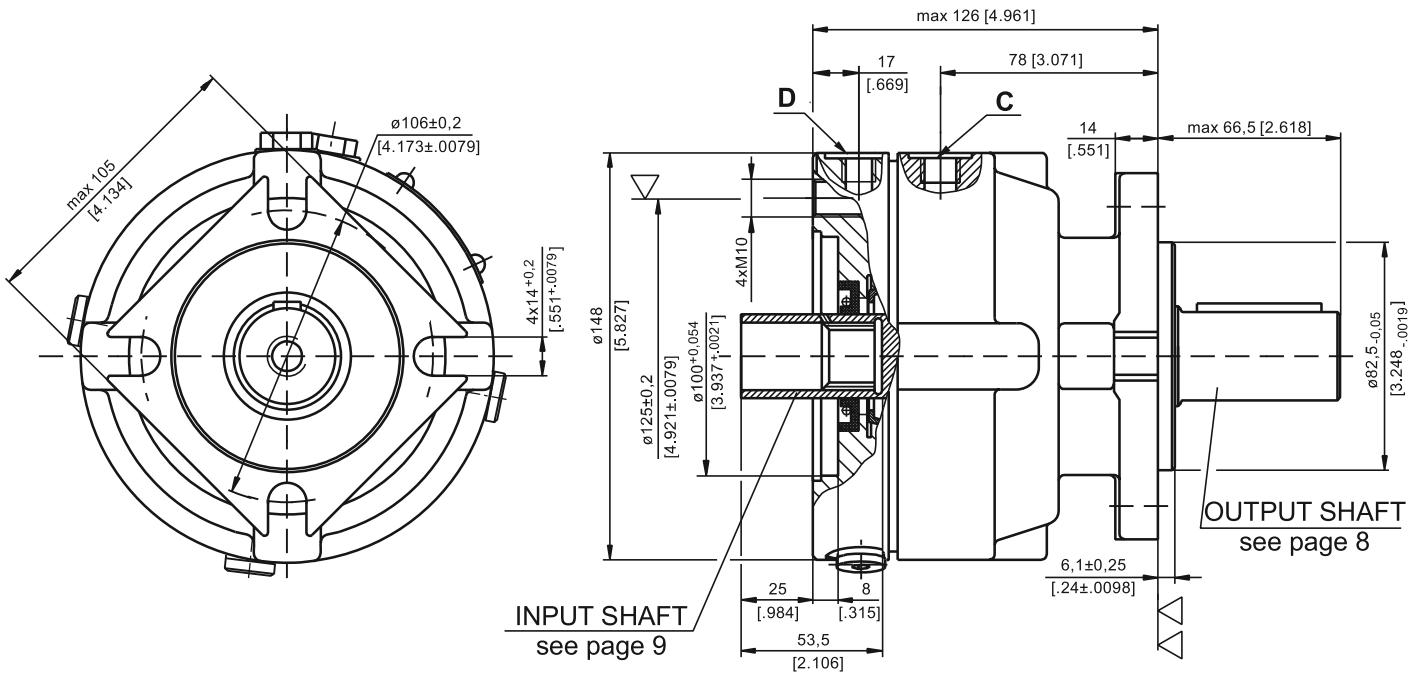

▽ - Place for attachment:

LBS - tightening torque for screw M10x35 - 8.8 DIN 912 - 5 daNm [440 lb-in]

LBV - tightening torque for screw M10xL - 12.9 DIN 931 - 6⁺ daNm [530⁹⁰ lb-in]

▽▽ - Place for attachment



mm [in]

C: Brake release Port - G¹/₄, 9 mm [0.35 in] depth

D: Drain plug for the Brake - G¹/₄, 9 mm [0.35 in] depth

T: Drain plug for the Motor - G¹/₄, 9 mm [0.35 in] depth

TYPE LBV/289

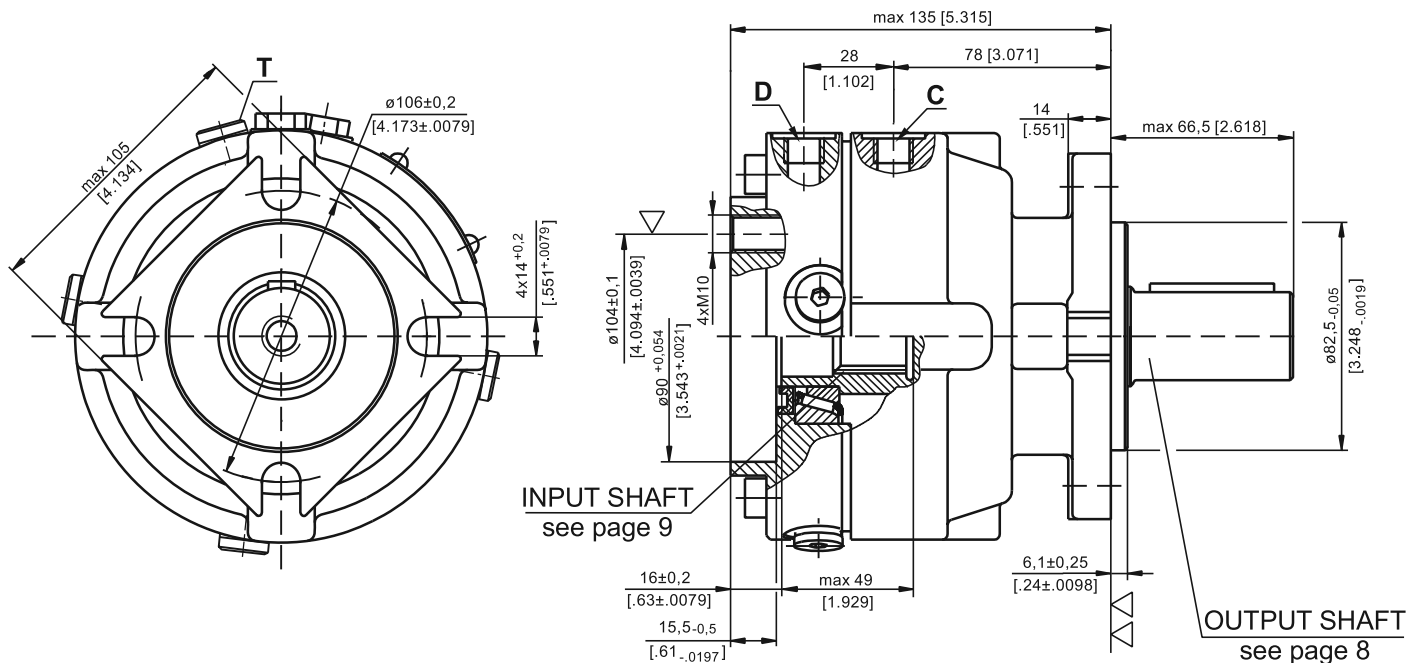

HYDRAULIC DISC BRAKE FOR FLANGE ATTACHMENT TO MSS AND MSV HYDRAULIC MOTORS

TYPE LBS/290

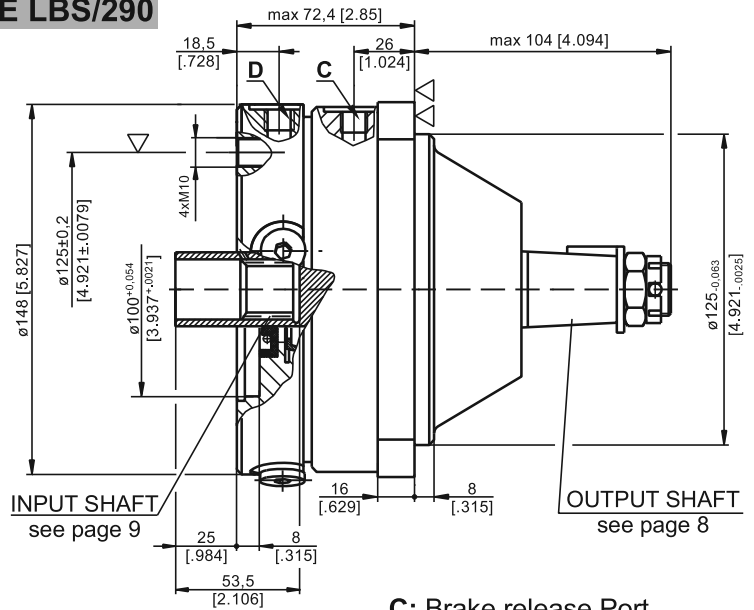
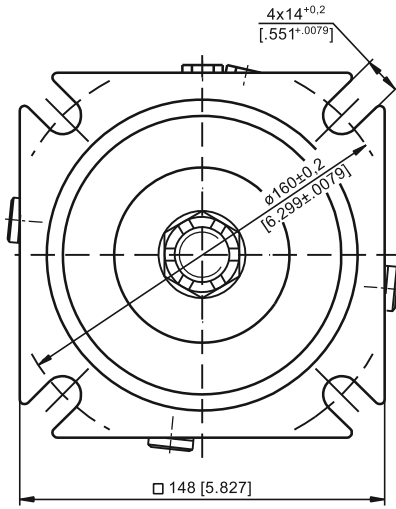

- ▽ - Place for attachment:
 LBS - tightening torque for screw M10x35 - 8.8 DIN 912 - 5 daNm [440 lb-in]
 LBV - tightening torque for screw M10xL - 12.9 DIN 931 - 6⁺ daNm [530⁹⁰ lb-in]
- ▽▽ - Place for attachment

- C:** Brake release Port
 - G¹/₄, 9 mm [.35 in] depth
- D:** Drain plug for the Brake
 - G¹/₄, 9 mm [.35 in] depth
- T:** Drain plug for the Motor
 - G¹/₄, 9 mm [.35 in] depth

TYPE LBV/290

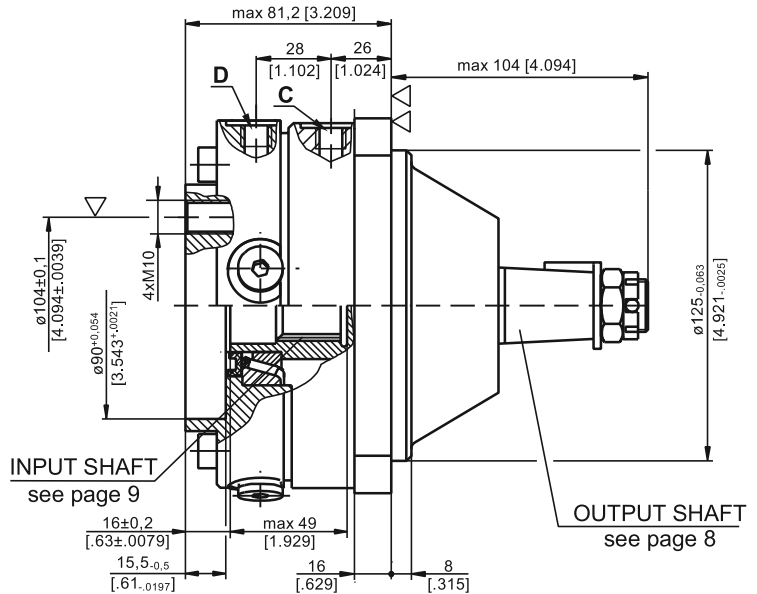
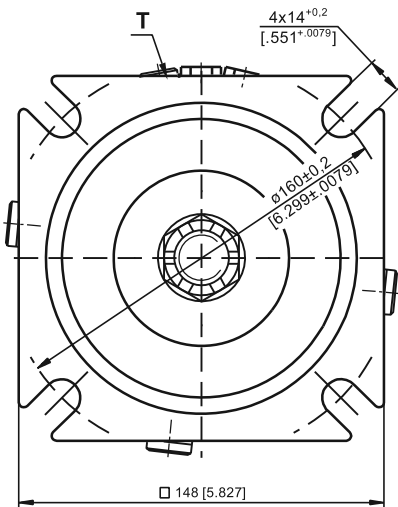

TYPE LBS/289(290)

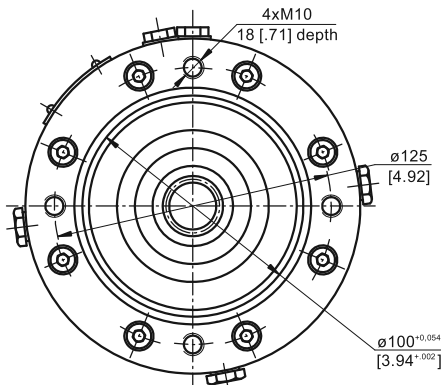

INPUT FACE For Versions 289 and 290

TYPE LBV/289(290)

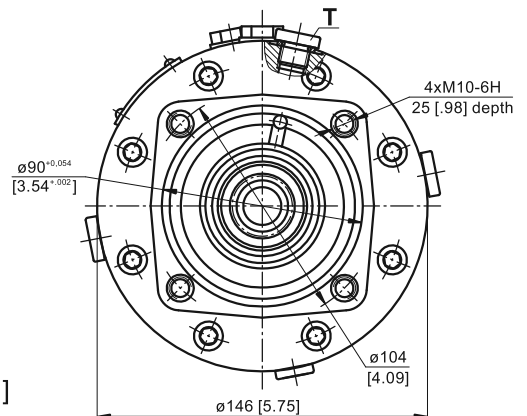

OUTPUT SHAFT EXTENSIONS

CB - $\varnothing 32$ straight, Parallel key A10x8x45 DIN 6885
Max. Torque 77 daNm [6815 lb-in]

KB - tapered 1:10, Parallel key B6x6x20 DIN 6885
Max. Torque 95 daNm [8400 lb-in]

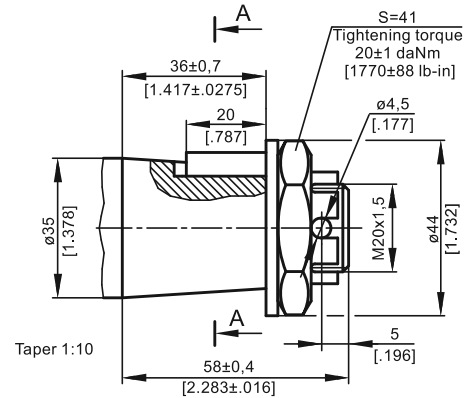
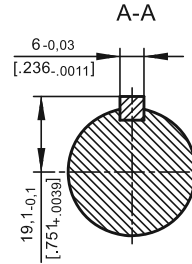
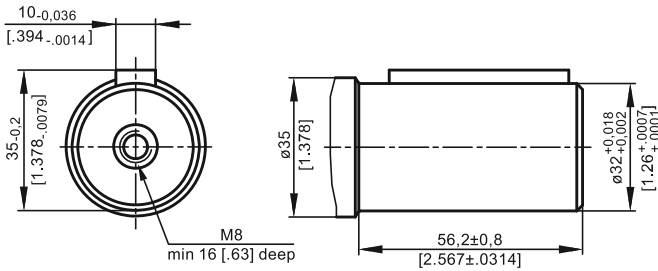

SH - $\varnothing 1\frac{1}{4}$ " splined 14T, DP12/24 ANS B92.1-1970
Max. Torque 95 daNm [8400 lb-in]

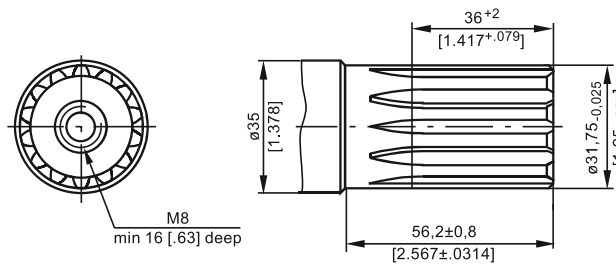

SPECIFICATION DATA

Description LBS/289(290) LBV/289(290)	21	32	43	63	L43	L63	
*Min. Static Torque, daNm [lb-in]	20-22 [1770-1947]	31-34 [2743-3009]	41-45 [3628-3982]	61-64 [5399-5665]	41-45 [3628-3982]	61-64 [5399-5665]	
Opening Pressure, bar [PSI]	min	12-13 [174-188]	18-20 [260-290]	24-26 [348-377]	37-39 [540-565]	20-22 [290-320]	21-23 [305-333]
	max	300 [4350]					
Min. oil quantity for brake releasing cm ³ [in ³]	7 - 8 [.427 - .488]						
Oil volume cm ³ [in ³]	50 - 120 [3.05 - 7.35]						
Max. Pressure in drain space bar [PSI]	5 [72]						
Weight kg [lb]	9 [19.8]						

* Static torque is obtained at working pressure - 0 bar [0 PSI].

INTERNAL SPLINE DATA FOR THE ATTACHED COMPONENT

Fillet Root Side Fit	LBS(V)/289 LBS(V)/290		LBS(V)/314 LBS(V)/315	
	mm	inch	mm	inch
Number of Teeth z	12	12	16	16
Diametral Pitch DP	12/24	12/24	12/24	12/24
Pressure Angle	30°	30°	30°	30°
Pitch Dia. D	25,4	1	33,8656	1.3333
Major Dia. D _{ri}	28,0 ^{-0,1}	1.1 ± 1.098	38,4 ^{+0,4}	1.5118±1.5275
Minor Dia. D _i	23,0 ^{+0,033}	.907 ± .905	32,15 ^{+0,06}	1.2657±1.2673
Space Width [Circular]Lo	4,308±0,020	.1704 ± .1688	4,516±0,037	.1763±.1791
Fillet Radius R	0,2	.008	0,5	.02
Max. Measurement L between Pins	17,62 ^{+0,15}	.699 ± .694	26,9 ^{+0,10}	1.063±1.059
Pin Dia. d	4,835±0,001	.19039±.19031	4,835±0,001	.19026±.19034
Corrected x.m	+0,8	+.031	+1,0	+.039

Standard ANS B92.1-1970, class 5
[m=2.1166]

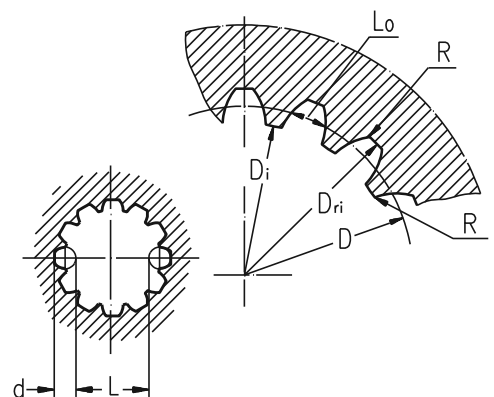

LOAD CURVE

The curve applies to a B10 bearing life of 3000 hours at 200 RPM

- 1: Pa<350 daN [787 lbs]
- 2: Pa=500 daN [1125 lbs]

LBS(V)/289

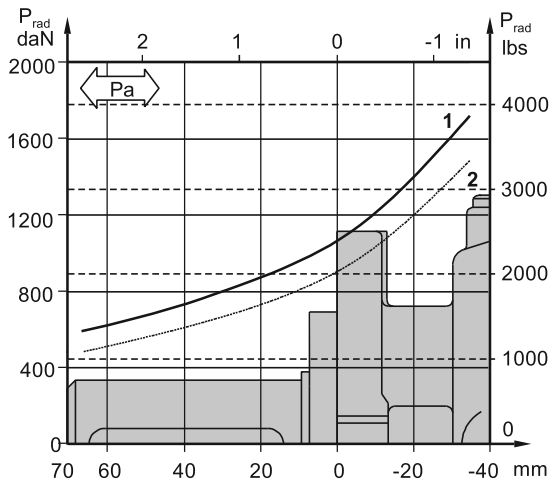

LBS(V)/290

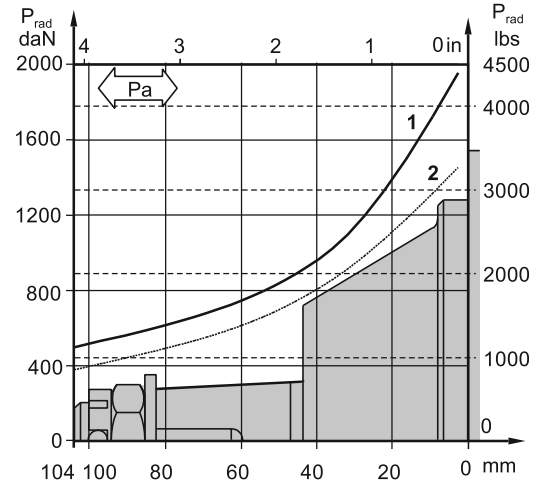

ORDER CODE - LB/288

1	2	3	4	5
LB/288	-			

Pos.1 - Input Shaft Hole

- C, CO, SH, CB, SB

Pos.2 - Static Torque code (See Specification data)

- 7, 14, 21, 32, 43, 63

Pos.3 - Output Shaft Extensions**

- C** - ø25 straight, Parallel key A8x7x32 DIN 6885
- CO** - ø1" straight, Parallel key ¼"x¼"x1¼" BS46
- SH** - ø25,32 splined BS 2059 (SAE 6B)
- SA** - ø24,5 splined B25x22 DIN 5482

CB - ø32 straight, Parallel key A10x8x45 DIN 6885

KB - ø35 tapered 1:10, Parallel key B6x6x20 DIN6885

Pos.4 - Option (Paint)***

- omit - no Paint
- P** - Painted
- PC** - Corrosion Protected Paint

Pos.5 - Design Series

- omit - Factory specified

ORDER CODE - LBS, LBV

1	2	3	4	5	6
LB	/	-			

Pos.1 - Type

- S** - Disc Brake for short motor S- MSS
- V** - Disc Brake for very short motor V- MSV

Pos.2 - Design code

- 289** - for MSS and MSV Motors
- 290** - for MSS and MSV Motors (Wheel Mount)

Pos.3 - Static Torque code (See Specification data)

- 21, 32, 43, 63, L43, L63

Pos.4 - Output Shaft Extensions*

- CB** - ø32 straight, Parallel key A10x8x45 DIN 6885
- KB** - ø35 tapered 1:10, Parallel key B6x6x20 DIN6885
- SH** - ø1¼" splined 14T ANS B92.1-1970

Pos.5 - Option (Paint)**

- omit - no Paint
- P** - Painted
- PC** - Corrosion Protected Paint

Pos.6 - Design Series

- omit - Factory specified

NOTES:

- * The permissible output torque for shafts must not be exceeded! For Max. Torque values see data on pages 5 and 8.
- ** The color is by customer's request.

The Disc Brakes are mangano-phosphatized as standard.

ATTENTION:

1. Hydraulic brake is delivered without oil (it is lubricated only).
2. Hydraulic brake is filled through the drain port **D**. Space is filled with 50 ÷ 120 cm³ [3.05÷7.32 in³] mineral oil HLP (DIN 51524) or HM (ISO 6743/4). For LB/288 fill oil after hydraulic motor assembly.
3. In all brakes, friction discs and separators should be lubricated.

**HYDRAULIC DISC BRAKES
FOR FLANGE ATTACHMENT TO MTS AND MTV HYDRAULIC MOTORS**

TYPE LBS/314

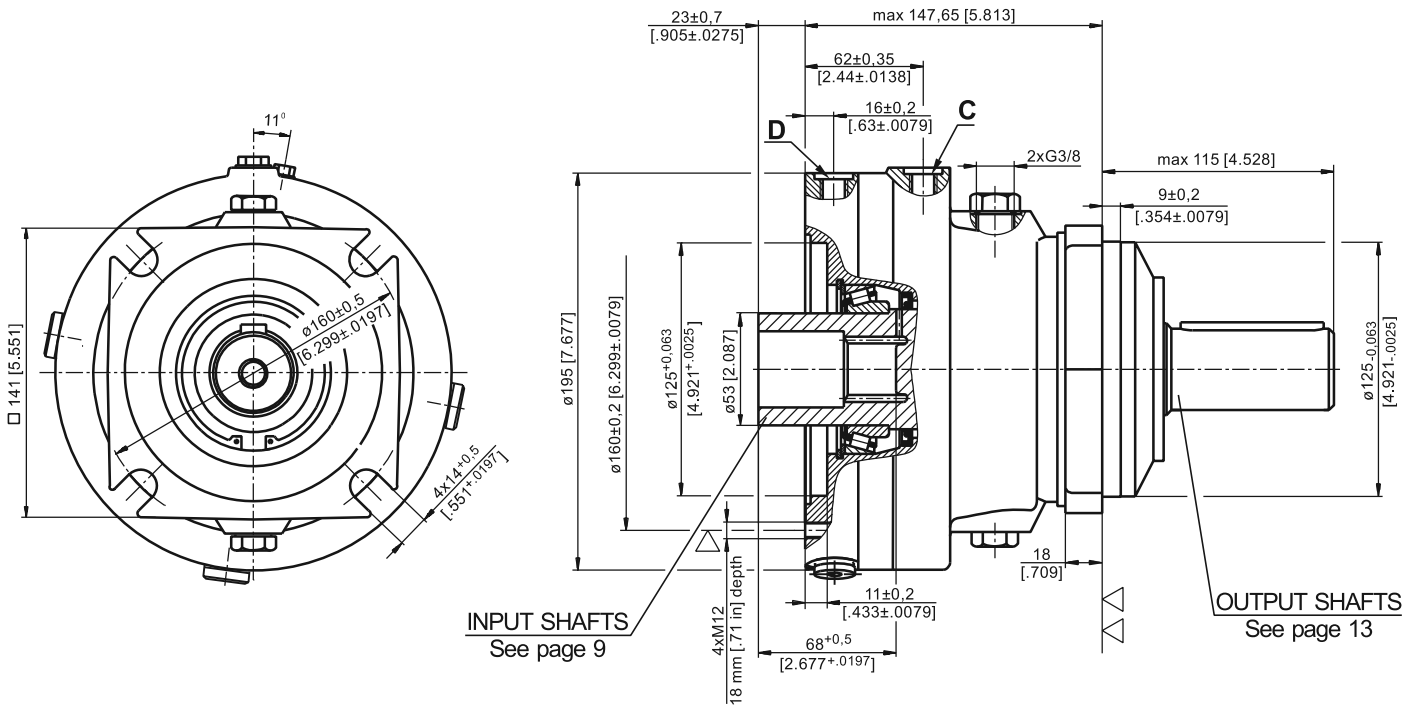

▽ - Place for attachment
(tightening torque for screw M12x30- 8.8 DIN 912,
7 daNm [620 lb-in])

C: Brake release Port - G $\frac{1}{4}$, 12 mm [.47 in] depth
D: Drainage tap - G $\frac{1}{4}$, 12 mm [.47 in] depth

▽▽ - Place for attachment

TYPE LBV/314

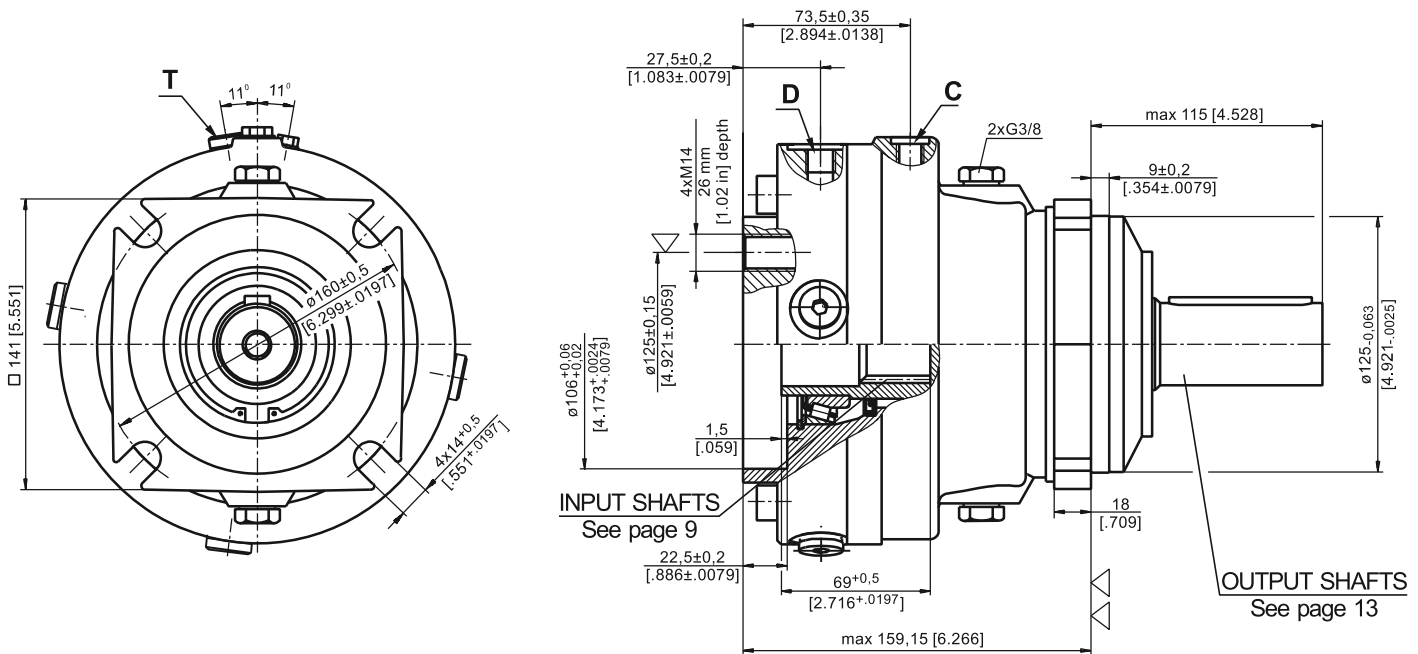

▽ - Place for attachment
(tightening torque for screw M14xL - 8.8 DIN 912,
11,5 daNm [1020 lb-in])

C: Brake release Port - G $\frac{1}{4}$, 9 mm [.35 in] depth
D: Drain plug for the Brake - G $\frac{1}{4}$, 9 mm [.35 in] depth
T: Drain plug for the Motor - G $\frac{1}{4}$, 9 mm [.35 in] depth

▽▽ - Place for attachment

**HYDRAULIC DISC BRAKES
FOR FLANGE ATTACHMENT TO MTS AND MTV HYDRAULIC MOTORS**

TYPE LBS/315

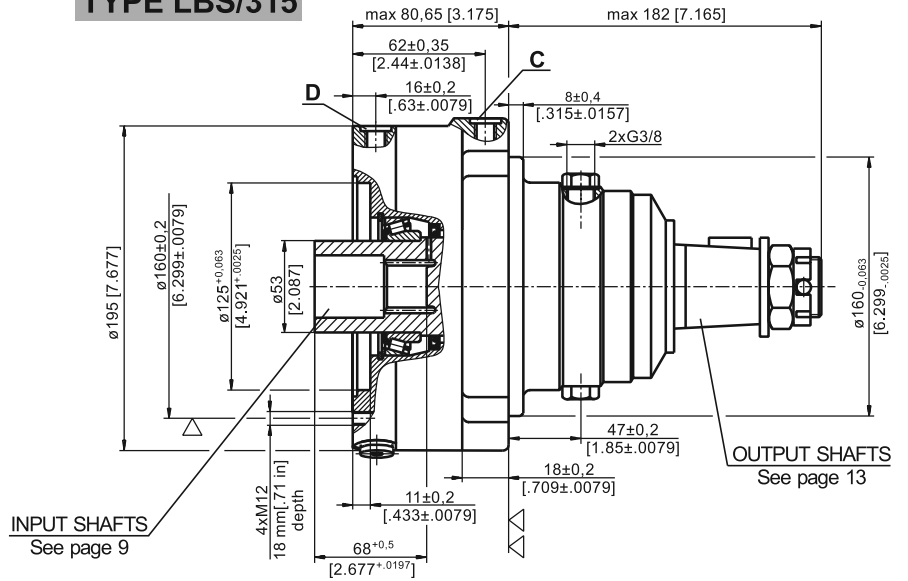
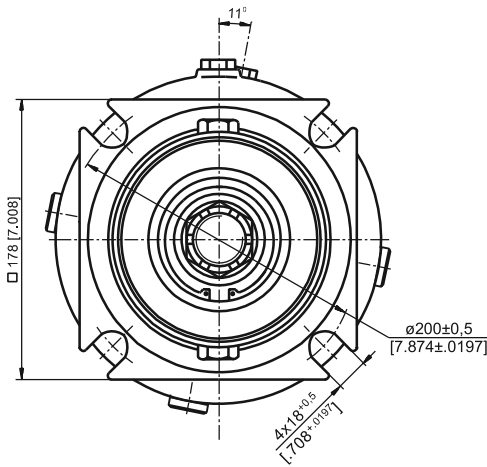

▽ - Place for attachment (tightening torque for screw M12x30- 8.8 DIN 912, 7 daNm [620 lb-in])
▽▽ - Place for attachment

C: Brake release Port - G $\frac{1}{4}$, 12 mm [.47 in] depth
D: Drainage tap - G $\frac{1}{4}$, 12 mm [.47 in] depth

TYPE LBV/315

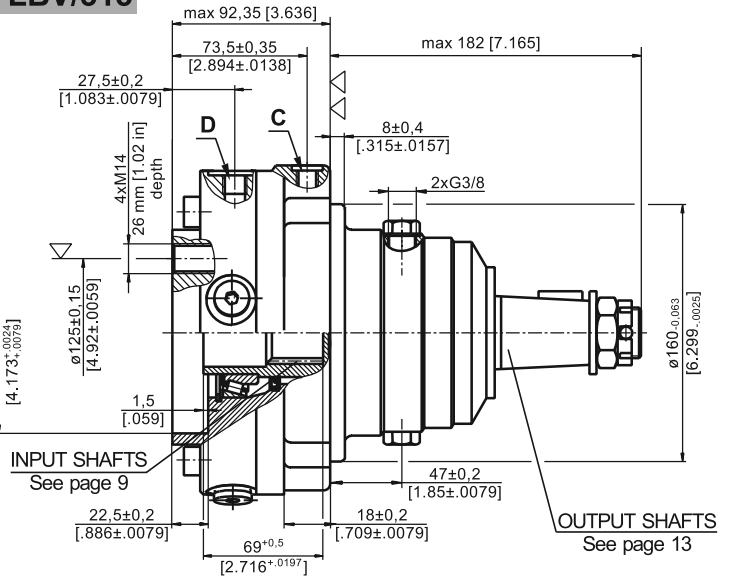
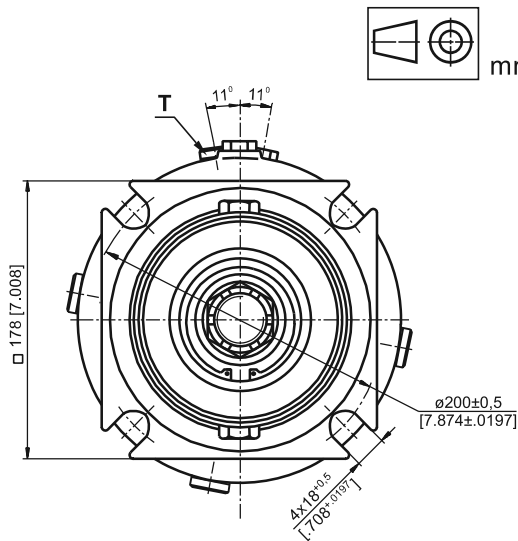

▽ - Place for attachment (tightening torque for screw M14xL- 8.8 DIN 912, 11,5 daNm [1020 lb-in])
▽▽ - Place for attachment

C: Brake release Port - G $\frac{1}{4}$, 9 mm [.35 in] depth
D: Drain plug for the Brake - G $\frac{1}{4}$, 9 mm [.35 in] depth
T: Drain plug for the Motor - G $\frac{1}{4}$, 9 mm [.35 in] depth

**INPUT FACE
For Versions 314 and 315**

TYPE LBS/314(315)

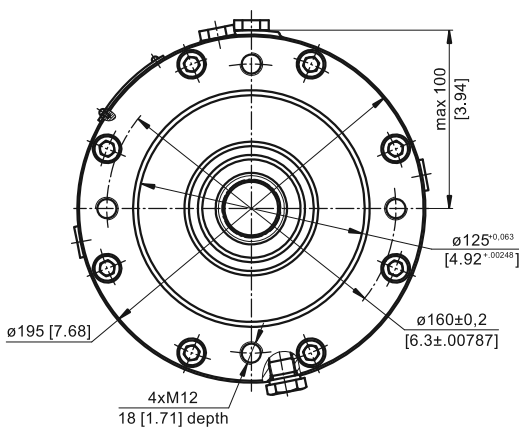

TYPE LBV/314(315)

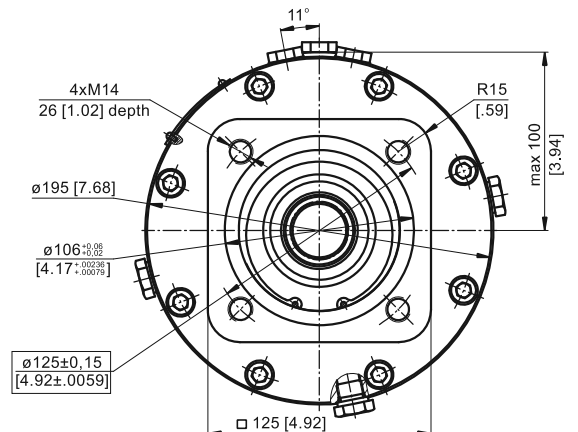

SPECIFICATION DATA

Description	LBS/314,315	21	29	43	65	85	110	130
*Min. Static Torque, daNm [lb-in]		18-23 [1593-2036]	28-33 [2478-2921]	42-46 [3717-4071]	61-70 [5399-6196]	83-92 [7346-8143]	108-118 [9559-10444]	126-136 [11152-12037]
Opening Pressure bar [PSI]	min**	4-5 [58-72]	6-7 [87-101]	9-10 [130-145]	13-15 [188-217]	18-20 [261-290]	23-25 [333-362]	27-29 [391-420]
	max	300 [4350]						
Min. oil quantity for brake releasing cm ³ [in ³]		8-9 [.488-.549]						
Oil volume cm ³ [in ³]		250						
Max. Pressure in drain space bar [PSI]		5 [72]						
Weight for .../314 .../315	kg [lb]	24 [52.9]						
		25 [55.1]						

*Static torque is obtained at working pressure - 0 bar.

**The indicated value is a difference between the inlet pressure for driving of the brake and the drain pressure.

Brakes must always have a drain line

LOAD CURVE

LBS(V) ... /314

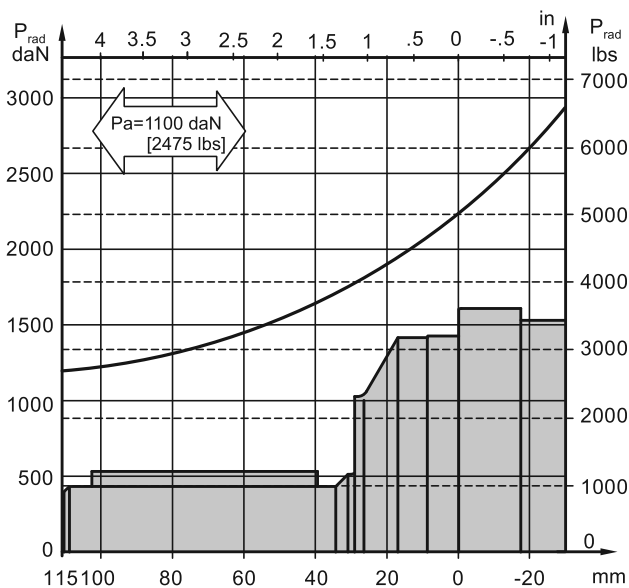

LBS(V) ... /315

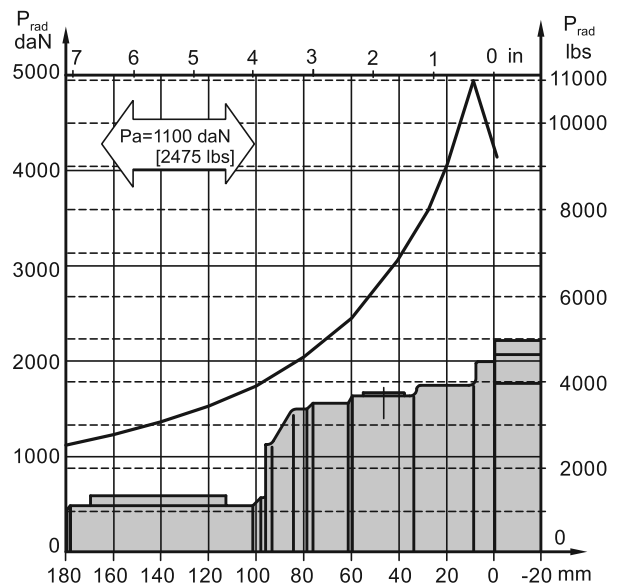

OUTPUT SHAFT EXTENSIONS

C - $\varnothing 40$ straight, Parallel key A12x8x70 DIN 6885
Max. Torque 132,8 daNm [11755 In-in]

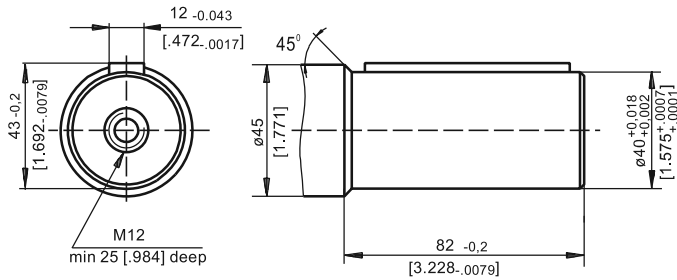

K -tapered 1:10, Parallel key B12x8x28 DIN 6885
Max. Torque 210,7 daNm [18650 lb-in]

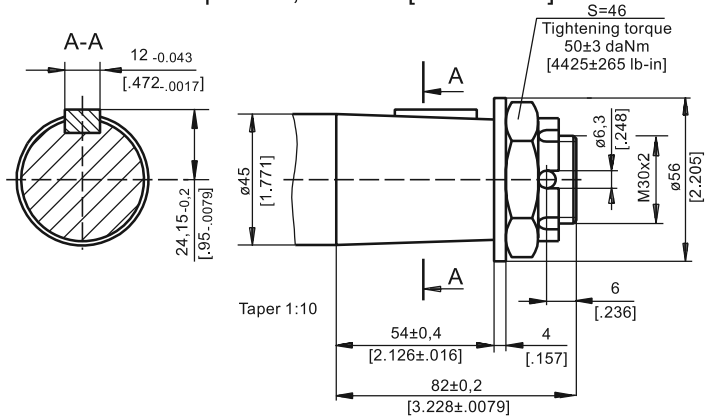

CO - $\varnothing 1\frac{1}{2}$ " straight, Parallel key $\frac{3}{8}$ "x $\frac{3}{8}$ "x $2\frac{1}{4}$ " BS46
Max. Torque 132,8 daNm [11755 In-in]

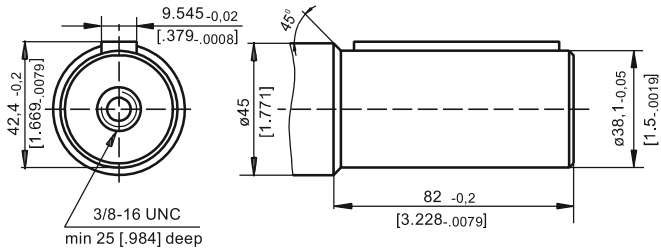

SH - $\varnothing 1\frac{1}{2}$ " splined 17T, DP 12/24 ANSI B92.1-1976
Max. Torque 132,8 daNm [11755 In-in]

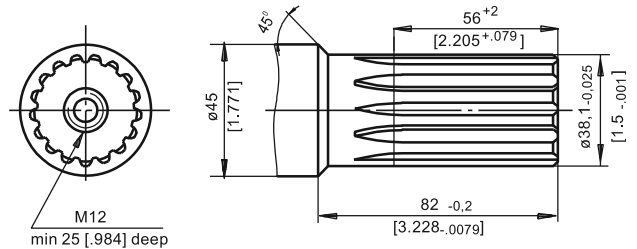

ORDER CODE

1	2	3	4	5	6
LB	/	-			

Pos.1 - Type

- S** - Disc Brake for short motor **S** - MTS
- V** - Disc Brake for very short motor **V** - MTV

Pos.2 - Design code

- 314** - for MTS and MTV Motors
- 315** - for MTS and MTV Motors (Wheel Mount)

Pos.3 - Static Torque code (See Specification data)

21, 29, 43, 65, 85, 110, 130

Pos.4 - Output Shaft Extensions*

- C** - $\varnothing 40$ straight, Parallel key A12x8x70 DIN 6885
- CO** - $\varnothing 1\frac{1}{2}$ " straight, Parallel key $\frac{3}{8}$ "x $\frac{3}{8}$ "x $2\frac{1}{4}$ " BS46
- SH** - $\varnothing 1\frac{1}{2}$ " splined 17T, ANSI B92.1-1976
- K** - $\varnothing 45$ tapered 1:10, Parallel key B12x8x28 DIN6885

Pos.5 - Option (Paint)**

- omit - no Paint
- P** - Painted
- PC** - Corrosion Protected Paint

Pos.6 - Design Series

- omit - Factory specified

NOTES:

- * The permissible output torque for shafts must not be exceeded!
- ** The color is by customer's request.

The Disc Brakes are manganophosphatized as standard.

ATTENTION:

- Hydraulic brake is delivered without oil (it is lubricated only).
- Fill the brake through the drain port **D** with $50 \div 120 \text{ cm}^3$ [$3.05 \div 7.32 \text{ in}^3$] mineral oil HLP (DIN 51524) or HM (ISO 6743/4). LB/288 must be filled after the motor is assembled on the brake.
- In all brakes, friction discs and separators should be lubricated.

**HYDRAULIC DISC BRAKES
FOR FLANGE ATTACHMENT TO MVS HYDRAULIC MOTORS**

Type LBS/313

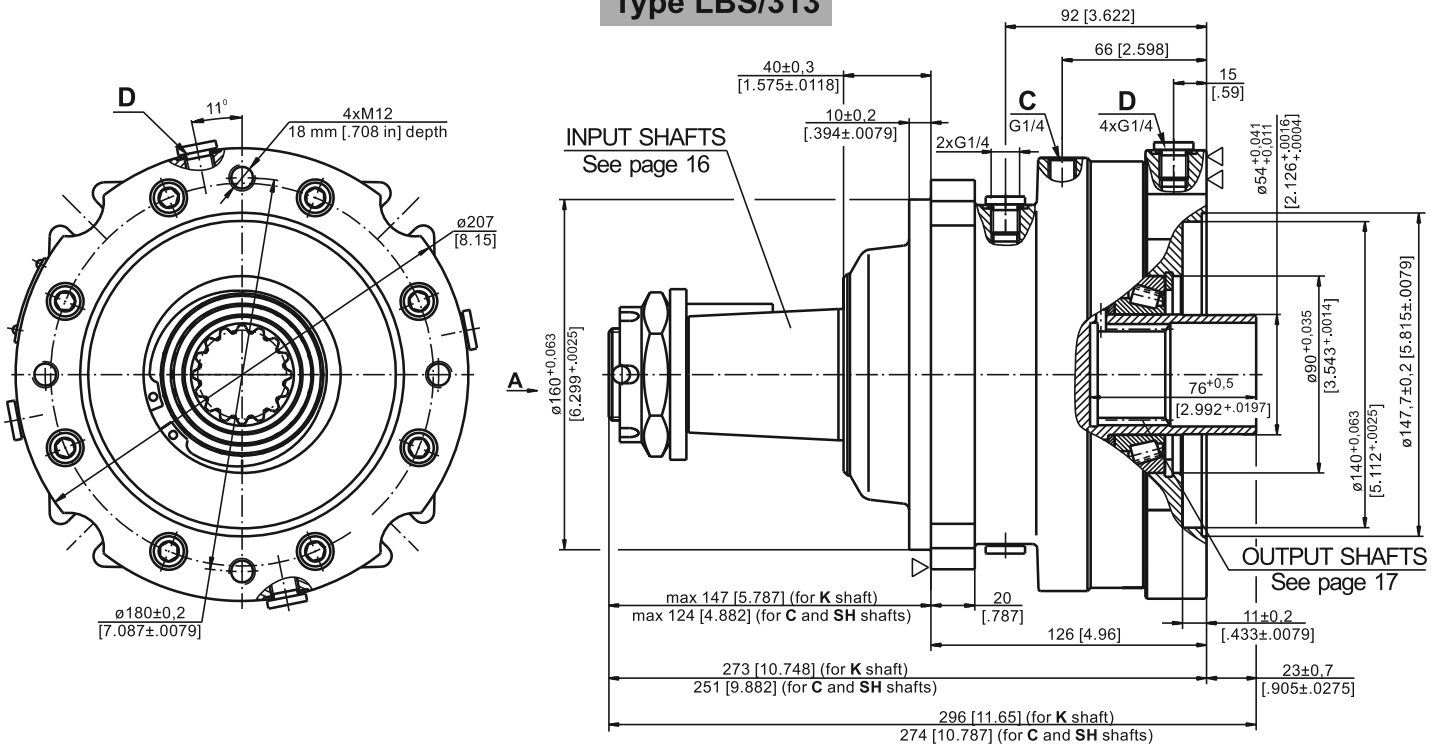

C: Brake release Port - G $\frac{1}{4}$, 12 mm [0.47 in] depth

D: Drainage tap - G $\frac{1}{4}$, 12 mm [0.47 in] depth

▽- Place for attachment

▽▽- Place for attachment
(tightening torque for screw M12x35 - 8.8 DIN 912,
7 daNm [620 lb-in])

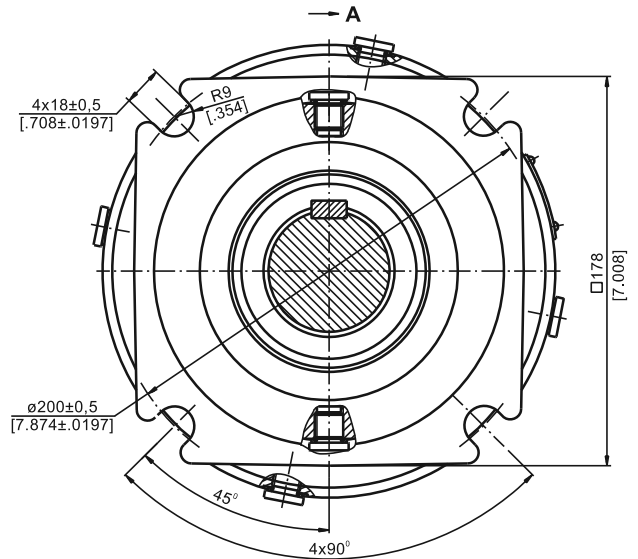

PERMISSIBLE SHAFT LOADS

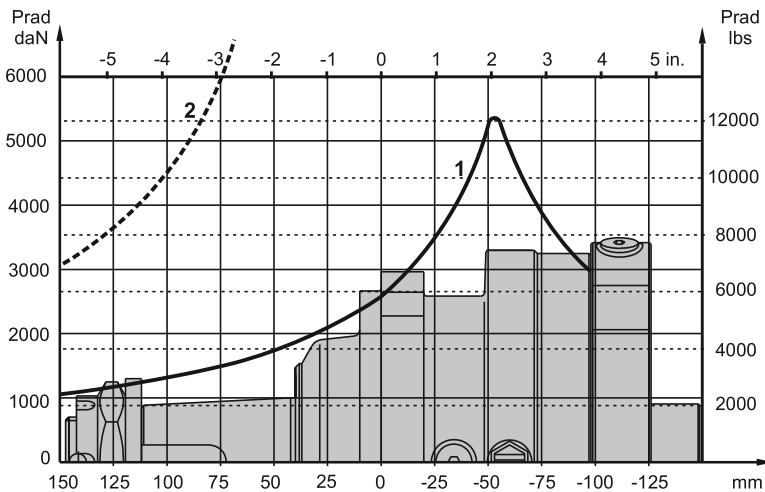

- 1 - Bearing curve: The curve applies to a B10 bearing life of 3000 hours at 200 RPM.
- 2 - Shaft curve: The curve represents Max. permissible radial shaft load with safety factor 3:1.

**HYDRAULIC DISC BRAKES
FOR FLANGE ATTACHMENT TO MVS HYDRAULIC MOTORS**

Type LBS/316

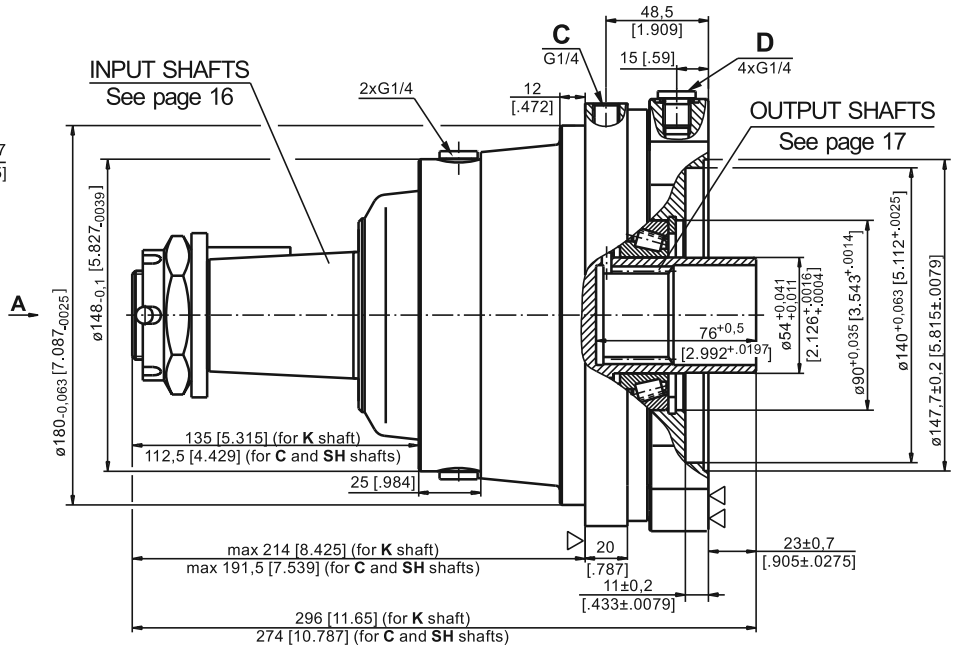
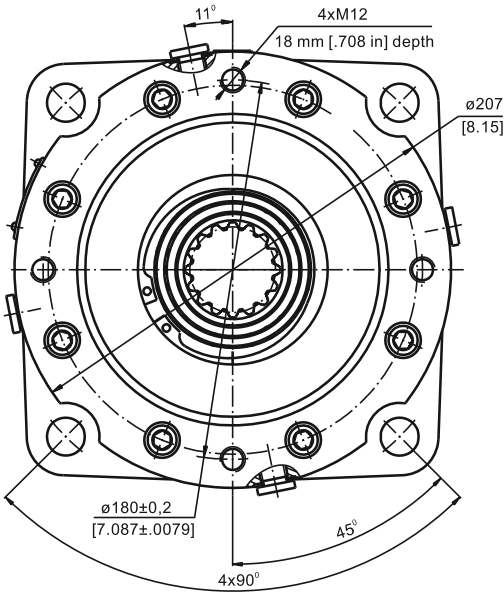

C: Brake release Port - G $\frac{1}{4}$, 12 mm [0.47 in] depth

D: Drainage tap - G $\frac{1}{4}$, 12 mm [0.47 in] depth

▽- Place for attachment

▽▽- Place for attachment
(tightening torque for screw M12x35 - 8.8 DIN 912,
7 daNm [620 lb-in])

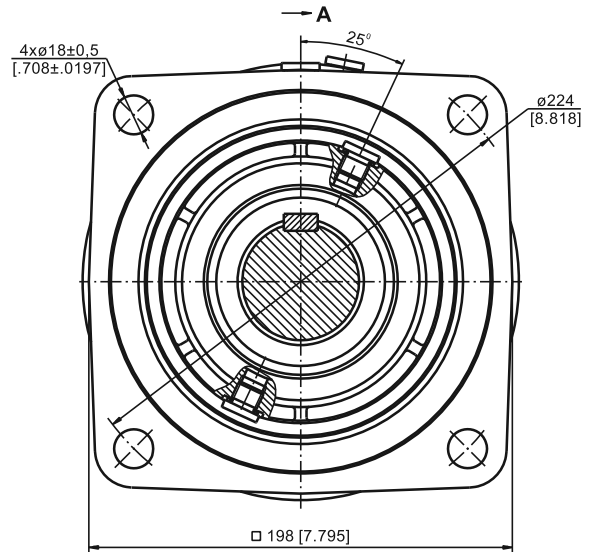

PERMISSIBLE SHAFT LOADS

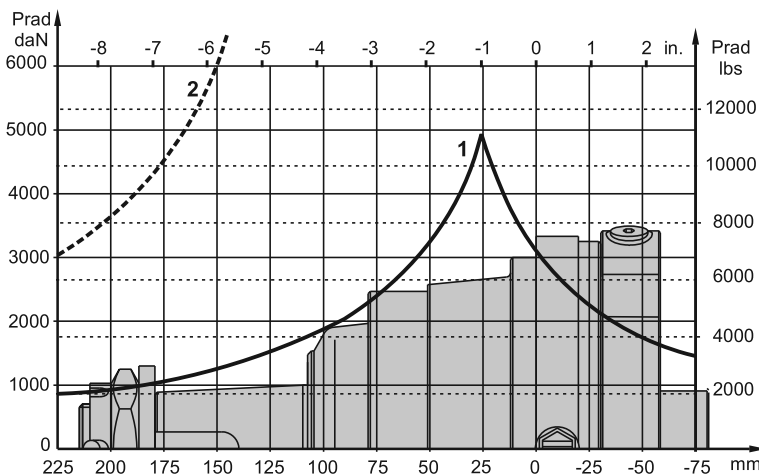

- 1 - Bearing curve:** The curve applies to a B10 bearing life of 3000 hours at 200 RPM.
- 2 - Shaft curve:** The curve represents Max. permissible radial shaft load with safety factor 3:1.

SPECIFICATION DATA

Description LBS/313,316	21	29	43	65	85	110	130
*Min. Static Torque, daNm [lb-in]	18-23 [1593-2036]	28-33 [2478-2921]	42-47 [3717-4160]	61-71 [5399-6285]	83-94 [7346-8320]	108-118 [9559-10444]	127-137 [11240-12125]
Opening Pressure min** bar [PSI]	4-5 [58-72]	6-7 [87-101]	9-10 [130-145]	13-15 [188-217]	18-20 [261-290]	23-25 [333-362]	27-29 [391-420]
	max 300 [4350]						
Min. oil quantity for brake releasing cm ³ [in ³]	8 ÷ 9 [.488 ÷ .549]						
Oil volume cm ³ [in ³]	250 [15.25]						
Max. Pressure in drain space bar [PSI]	5 [72]						
Weight for .../313 kg [lb]	25 [55.1]						
	.../316	26 [57.3]					

*Static torque is obtained at working pressure - 0 bar.

**The indicated value is a difference between the inlet pressure for driving of the brake and the drain pressure.

Brakes must always have a drain line

SHAFT EXTENSIONS

C - ø50 straight, Parallel key A14x9x70 DIN 6885

SH -ø21/8"splined, 16 DP 8/16 ANS B92.1-1976

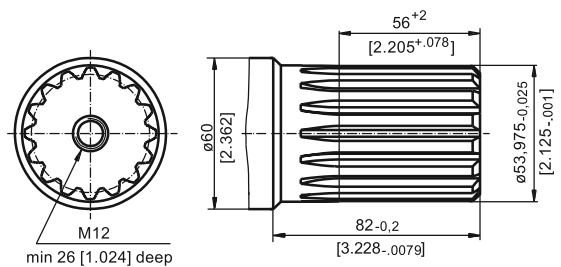
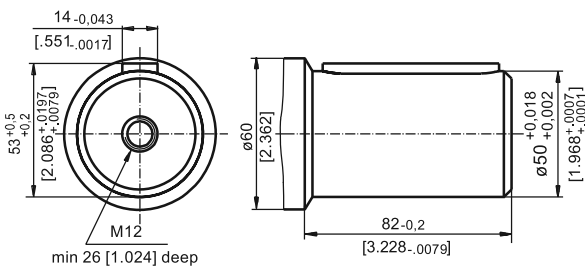

K -tapered 1:10, Parallel key B16x10x32 DIN 6885

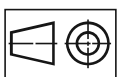
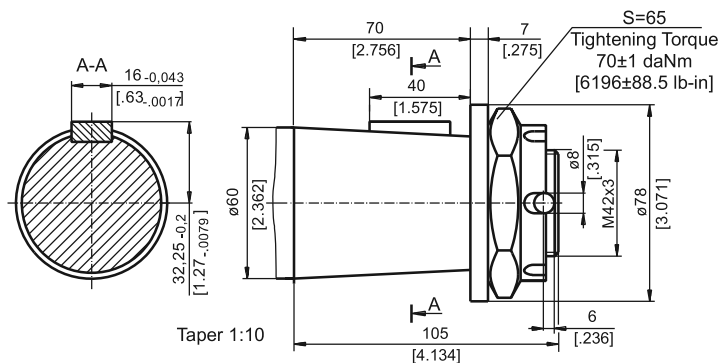

mm [in]

INTERNAL SPLINE DATA FOR THE ATTACHED COMPONENT

Standard ANS B92.1-1970, class 5
[$m=2.54$; corrected $x.m=+1,0$]

Fillet Root Side Fit		mm	inch
Number of Teeth	z	16	16
Diametral Pitch	DP	10/20	10/20
Pressure Angle		30°	30°
Pitch Dia.	D	40,640	1.6
Major Dia.	D _{ri}	45,2 ^{+0,4}	1.796÷1.780
Minor Dia.	D _i	38,5 ^{+0,039}	1.5175÷1.516
Space Width [Circular]	L _o	5,18±0,037	.2055÷.2025
Fillet Radius	R	0,4	.015
Max. Measurement between Pins	L	32,47 ^{+0,15}	1.284÷1.278
Pin Dia.	d	5,6±0,001	.22051÷.22043

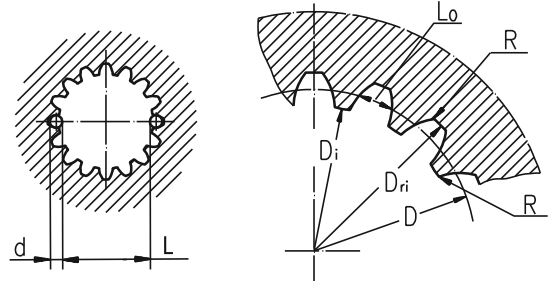

Hardening Specification:
HV=750±50 on the surface.
HV=560 at 0,7±0,2 mm [.035±.019in] case depth
Material: 20 MoCr4 EN 10084 or better.

ORDER CODE

	1	2	3	4	5
LBS/		-			

Pos.1 - Designe code

313 - for MVS Motors

316 - for MVS Motors (Wheel mount)

Pos.2 - Static Torque code (See Specification data)

21, 29, 43, 65, 85, 110, 130

Pos.3 - Output Shaft Extensions*

C - ø50 straight, Parallel key A14x9x70 DIN6885

SH - ø2 1/8" splined, ANSI B92.1-1976

K - ø60 tapered 1:10, Parallel key B16x10x32 DIN6885

Pos.4 - Option (Paint)**

omit - no Paint

P - Painted

PC - Corrosion Protected Paint

Pos.5 - Design Series

omit - Factory specified

NOTES:

* The permissible output torque for shafts must be not exceeded!

** The color is by customer's request.

The Disc Brakes are mangano-phosphatized as standard.

ATTENTION:

1. Hydraulic brake is delivered without oil (it is lubricated only).

2. In all brakes, friction discs and separators should be lubricated. Space is filled with 150 ÷ 300 cm³ [9.15 ÷ 18.3 in³] mineral oil HLP (DIN 51524) or HM (ISO 6743/4).

HYDRAULIC DISC BRAKES B...R- Wet

B...R brake is designed to be mounted to the wheels of low-speed agricultural and construction vehicles.

The advantage of these brakes is that despite the smallest possible dimensions they preserve long-term life of the bearings at high radial shaft load.

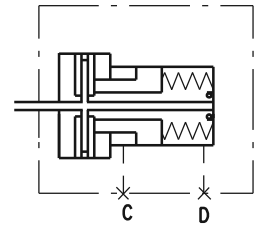

SPECIFICATION DATA

Type	B35R	B55R
Static Torque of Brake, daNm [lb-in]*	35 [3100]	55 [4870]
Initial Release Pressure, bar [PSI]	16 [232]	16 [232]
Full Release Pressure, bar [PSI]	19 [275]	19 [275]
Max. Operating Pressure, bar [PSI]	240 [3480]	240 [3480]
Max. Speed, RPM	90	90
Cont. Radial Shaft Load daN [lbs]**	500 [1125]	500 [1125]
Max. Radial Shaft Load daN [lbs]***	700 [1575]	900 [2030]

* At 0 bar [0 PSI] back pressure

** At radial shaft load of 500 daN [1125 lbs], applied at center-line of the key and speed of rotation 90 RPM, the bearing life is 1000 hours.

*** The permissible values of radial shaft load may occur for max. 10% of every minute

DIMENSIONS AND MOUNTING DATA

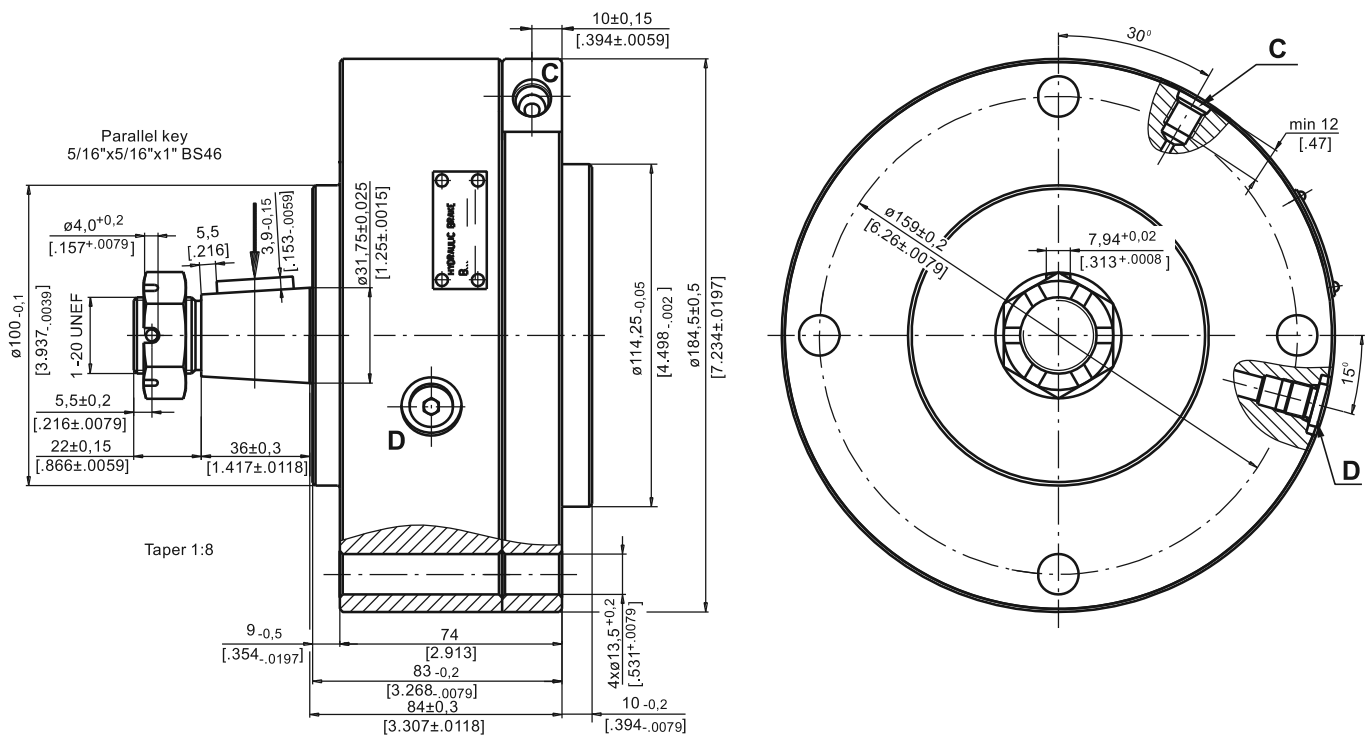

C : Brake Release Port -7/16-20 UNF
SAE J1926-1/ISO 11926-1

D : Drainage Tap - 7/16-20 UNF



